

To: (b) (6), (b) (7)(C)]
From: (b) (6), (b) (7)(C)]
Sent: Tue 6/29/2021 2:41:25 PM
Subject: Re: Assistance body-worn camera accountability

We will be using both of the below cameras.

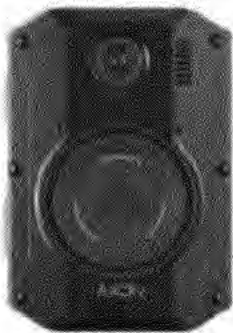
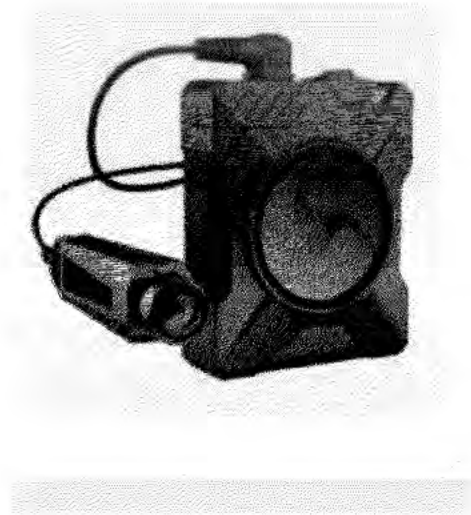

BODY 3

ATF Senior Special Agent/Digital Evidence Management Systems Project Officer (b) (6), (b) (7)(C)

On Jun 29, 2021, at 6:22 AM, (b) (6), (b) (7)(C)]
wrote:

(b) (6), (b) (7)(C)], could you send me a picture of the camera.

Thank you

(b) (6), (b) (7)(C)

Chief, Property Management Section
Materiel Management Branch
Bureau of Alcohol, Tobacco, Firearms and Explosives
Room 3S181
99 New York Avenue, NE
Washington, DC 20226

(D) (b) (6), (b) (7)(C)

(C) (b) (6), (b) (7)(C)

(F) (b) (6), (b) (7)(C)

From: (b) (6), (b) (7)(C)

Sent: Tuesday, June 29, 2021 5:51 AM

To: (b) (6), (b) (7)(C)

Cc: (b) (6), (b) (7)(C)

Subject: RE: Assistance body-worn camera accountability

Good morning (b) (6), (b) (7)(C)

I have copy furnished (b) (6), (b) (7)(C), the MMB Property Section Chief, who will reach out to you to coordinate this effort.

From: (b) (6), (b) (7)(C)

Sent: Monday, June 28, 2021 8:36 PM

To: (b) (6), (b) (7)(C)

Subject: Assistance body-worn camera accountability

Good evening,

As you may or may not be aware, per the Deputy Attorney General's directive, ATF is developing a body-worn camera program for ATF special agents. Phase one of the program implementation includes the deployment of hardware to include body-worn cameras (220) and the associated accessories. The initial deployment of cameras will be distributed to the following locations; Phoenix FD, Detroit FD and the ATF National Academy. I am hoping for suggestions and guidance as to the most efficient way to pin these items. Cameras deployed to the Field Divisions will be assigned to the individual agents while the academy cameras will remain at the academy. The cameras will need to be pinned and assigned before the scheduled training in August.

Any suggestions or assistance would be appreciated.

(b) (6), (b) (7)(C)

Alcohol, Tobacco, Firearms and Explosives
16009 N. 81st Street, Suite 100
Scottsdale, AZ 85260
Special Agent Project Officer-Digital Evidence Management
Technical Project Office
Special Operations Division

(b) (6), (b) (7)(C)

CONFIDENTIALITY NOTICE: E-mail may contain confidential information that is legally privileged. Do not read this e-mail if you are not the intended recipient.

This e-mail transmission, and any documents, files or previous e-mail messages attached to it may contain confidential information that is legally privileged. If you are not the intended recipient, or a person responsible for delivering it to the intended recipient, you are hereby notified that any disclosure, copying, distribution or use of any of the information contained in or attached to this transmission is STRICTLY PROHIBITED. If you have received this transmission in error, please immediately notify us by reply e-mail, by forwarding this to (b) (6), (b) (7)(C) or by telephone at (b) (6), (b) (7)(C) and destroy the original transmission and its attachments without reading or saving in any manner. Thank you.

To: (b) (6), (b) (7)(C)
From: (b) (6), (b) (7)(C)
Sent: Fri 7/16/2021 9:20:31 PM
Subject: RE: FPC Code

(b) (6), (b) (7)(C)

I was instructed the 1851.7 needed to be completed upon receipt of the hardware (body-worn cameras). Chief Vanderplow provided the following POC to establish the procedure of accounting for the cameras once they arrived. (b) (6), (b) (7)(C), Chief, Property Management Section Materiel Management Branch.

(b) (6), (b) (7)(C) also advised we could use serial numbers versus pin stickers. The cameras are being deployed to the Detroit FD, Phoenix, FD, and ATF National Academy as part of phase one of the ATF body-worn camera program. Once the field receives training (in August). They will be reassigned in sunflower to the corresponding divisions to be assigned to the individual agents. The Academy will maintain their cameras for training. I hope this helps!

Enjoy your weekend!

(b) (6), (b) (7)(C)
Alcohol, Tobacco, Firearms and Explosives
16009 N. 81st Street, Suite 100
Scottsdale, AZ 85260
Special Agent Project Officer-Digital Evidence Management
Technical Project Office
Special Operations Division
(b) (6), (b) (7)(C)

CONFIDENTIALITY NOTICE: E-mail may contain confidential information that is legally privileged. Do not read this e-mail if you are not the intended recipient.

This e-mail transmission, and any documents, files or previous e-mail messages attached to it may contain confidential information that is legally privileged. If you are not the intended recipient, or a person responsible for delivering it to the intended recipient, you are hereby notified that any disclosure, copying, distribution or use of any of the information contained in or attached to this transmission is STRICTLY PROHIBITED. If you have received this transmission in error, please immediately notify us by reply e-mail, by forwarding this to (b) (6), (b) (7)(C) or by telephone at (b) (6), (b) (7)(C) and destroy the original transmission and its attachments without reading or saving in any manner. Thank you.

From: (b) (6), (b) (7)(C)
Sent: Friday, July 16, 2021 1:26 PM
To: (b) (6), (b) (7)(C)
Subject: RE: FPC Code

Yes, 701200 is the correct FPC. Why are you sending them to Property Management Section? If someone told you to, that's fine, but we were never told to do that. Is that something required because of the BWC program? I'm just curious if I need to tell others to send their reports to them as well? Thanks!

And thanks for the response on the invoice. I will enter the ARG on Monday and follow up with an email. Have a nice weekend!

From: (b) (6), (b) (7)(C)
Sent: Friday, July 16, 2021 4:19 PM
To: (b) (6), (b) (7)(C)
Subject: FPC Code

(b) (6), (b) (7)(C)

I have completed the Receiving Reports and sent them to Property Management Section. Regarding the FPC code for the 1851.7, could you advise if, 701200 is the correct code?

(b) (6), (b) (7)(C)
Alcohol, Tobacco, Firearms and Explosives
16009 N. 81st Street, Suite 100
Scottsdale, AZ 85260
Special Agent Project Officer-Digital Evidence Management
Technical Project Office
Special Operations Division
(b) (6), (b) (7)(C)

CONFIDENTIALITY NOTICE: E-mail may contain confidential information that is legally privileged. Do not read this e-mail if you are not the intended recipient.

This e-mail transmission, and any documents, files or previous e-mail messages attached to it may contain confidential information that is legally privileged. If you are not the intended recipient, or a person responsible for delivering it to the intended recipient, you are hereby notified that any disclosure, copying, distribution or use of any of the information contained in or attached to this transmission is STRICTLY PROHIBITED. If you have received this transmission in error, please immediately notify us by reply e-mail, by forwarding this to (b) (6), (b) (7)(C) or by telephone at (b) (6), (b) (7)(C) and destroy the original transmission and its attachments without reading or saving in any manner. Thank you.

To: (b) (6), (b) (7)(C)
Cc: (b) (6), (b) (7)(C); (b) (6), (b) (7)(C); (b) (6), (b) (7)(C)
(b) (6), (b) (7)(C)
From: (b) (6), (b) (7)(C)
Sent: Thur 8/12/2021 4:25:57 PM
Subject: RE: PR Bonds - CORA Request - DPD
Denver Police Department PSN MOU (002).pdf

Here you go.

From: (b) (6), (b) (7)(C)
Sent: Thursday, August 12, 2021 9:11 AM
To: (b) (6), (b) (7)(C)
Cc: (b) (6), (b) (7)(C); (b) (6), (b) (7)(C); (b) (6), (b) (7)(C)
(b) (6), (b) (7)(C)
Subject: Re: PR Bonds - CORA Request - DPD

Would you mind forwarding a copy?

On Aug 12, 2021, at 12:01 PM (b) (6), (b) (7)(C) wrote:

(b) (6), (b) (7)(C)

The agreement has our standard disclosure language from the JLEO MOU templated. This is what it says:

Information will be freely shared among the TFOs, Special Deputies and ATF personnel with the understanding that all investigative information will be kept strictly confidential and will only be used in furtherance of criminal investigations. No information gathered during the course of the RAVEN Task Force, to include informal communications between TFOs, Special Deputies and ATF personnel, may be disseminated to any third party, non-task force member by any task force member without the express permission of the ATF Special Agent in Charge or his/her designee.

Any public requests for access to the records or any disclosures of information obtained by task force members during RAVEN Task Force federal investigations will be handled in accordance with applicable statutes, regulations, and policies pursuant to the Freedom of Information Act and the Privacy Act and other applicable federal and/or state statutes and regulations.

(b) (5)

I added (b) (6), (b) (7)(C) to the discussion.

Thanks.

(b) (6), (b) (7)

From: (b) (6), (b) (7)(C) >

Sent: Thursday, August 12, 2021 6:08 AM

To: (b) (6), (b) (7)(C) (b) (6), (b) (7)(C)

Cc: (b) (6), (b) (7)(C)

Subject: RE: PR Bonds - CORA Request - DPD

(b) (6), (b) (7)

(b) (5)

(b) (6), (b) (7)

From: (b) (6), (b) (7)(C)

Sent: Wednesday, August 11, 2021 6:45 PM

To: (b) (6), (b) (7)(C) >; (b) (6), (b) (7)(C)

Cc: (b) (6), (b) (7)(C)

Subject: FW: PR Bonds - CORA Request - DPD

(b) (6), (b) (7) and (b) (6), (b) (7)(C)

(b) (5)

(b) (6), (b) (7)(C)

From: (b) (6), (b) (7)(C)

Sent: Wednesday, August 11, 2021 3:20 PM

To: (b) (6), (b) (7)(C) (b) (6), (b) (7)(C)

Cc: (b) (6), (b) (7)(C) >; (b) (6), (b) (7)(C) @auroragov.org; (b) (6), (b) (7)(C)

(b) (6), (b) (7)(C) @denvergov.org>

Subject: FW: PR Bonds - CORA Request - DPD

(b) (5), (b) (6), (b) (7)(C)

From: (b) (6), (b) (7)(C)@auroragov.org>

Sent: Wednesday, August 11, 2021 4:13 PM

To: (b) (6), (b) (7)(C)@denvergov.org

Cc: (b) (6), (b) (7)(C)@denvergov.org>; (b) (6), (b) (7)(C)

(b) (6), (b) (7)(C)@denvergov.org>; (b) (6), (b) (7)(C)

(b) (6), (b) (7)(C)@denvergov.org>; (b) (6), (b) (7)(C)

(b) (6), (b) (7)(C); (b) (6), (b) (7)(C)>; (b) (6), (b) (7)(C)

(b) (6), (b) (7)(C)

Subject: Re: PR Bonds - CORA Request - DPD

Hi Commander and (b) (6), (b) (7)(C)

Sorry I'm in the car. The MOU for RAVEN involving DPD was recently signed by Chief Montoya. The US Attorney's Office will not be associated to the RAVEN MOU. They were erroneously placed in there and are removed.

Based on the info below and with regards to the CORA request, that would be an MOU between Denver and the ATF specifically for the newly formed unit.

I'm pretty sure you (DPD) has a specific MOU with Denver dated back several years.

The best way to track that down would be through ATF. I am copying SAC Booth and (b) (6), (b) (7)(C) (b) (6), (b) (7)(C)

Please let me know if I'm wrong with this thinking.

(b) (6), (b) (7)(C)

Sent from my iPhone

On Aug 11, 2021, at 3:59 PM, (b) (6), (b) (7)(C) (b) (6), (b) (7)(C)@denvergov.org> wrote:

Commander,

There is definitely an MOU that addresses our partnership and I'm sure the department has a copy. Now, I'm not sure who retains that, but if it cannot be quickly located I'm sure Lt (b) (6), (b) (7)(C) can dig one up.

From: (b) (6), (b) (7)(C) (b) (6), (b) (7)(C)@denvergov.org>

Sent: Wednesday, August 11, 2021 3:40 PM

To: (b) (6), (b) (7)(C)@denvergov.org>; (b) (6), (b) (7)(C)

(b) (6), (b) (7)(C)@denvergov.org>

Cc: (b) (6), (b) (7)(C)

(b) (6), (b) (7)(C)@denvergov.org>; (b) (6), (b) (7)(C)@auroragov.org

Subject: FW: PR Bonds - CORA Request - DPD

(b) (6), (b) (7)(C) (b) (6), (b) (7)(C)

I know we have a partnership between ATF / Aurora on the RAVEN side, could you clarify with (b) (6), (b) (7)(C)

Thank you,

(b) (6), (b) (7)(C)

<image001.png>

(b) (6), (b) (7)(C) | Commander
Denver Police Department | Special Operations Division
(b) (6), (b) (7)(C) Phone | (b) (6), (b) (7)(C) Cell
1331 Cherokee St. Denver CO 80204
(b) (6), (b) (7)(C) @denvergov.org

From: (b) (6), (b) (7)(C)
(b) (6), (b) (7)(C) @denvergov.org>

Sent: Wednesday, August 11, 2021 9:44 AM

To: (b) (6), (b) (7)(C) @denvergov.org>;
(b) (6), (b) (7)(C) @denvergov.org>; (b) (6), (b) (7)(C)
(b) (6), (b) (7)(C) @denvergov.org>; (b) (6), (b) (7)(C)
(b) (6), (b) (7)(C) @denvergov.org>

Subject: RE: PR Bonds - CORA Request - DPD

Hi Cmdr,
I'm just following up on this email from last week. Is there any documentation for the partnership between DPD and the Feds/USADA's?

Thanks!

(b) (6), (b) (7)(C) | Crime Analyst
Denver Police Department Special Operations Response Team (SORT) | City and County of Denver
Pronouns | She/Her/Hers
p: (b) (6), (b) (7)(C) c: (b) (6), (b) (7)(C) | (b) (6), (b) (7)(C) @denvergov.org

In office: Monday, Tuesday, and Thursday
Remote: Wednesday and Friday
<image002.jpg>

From: (b) (6), (b) (7)(C)

Sent: Thursday, August 05, 2021 1:36 PM

To: (b) (6), (b) (7)(C) @denvergov.org>;
(b) (6), (b) (7)(C) @denvergov.org>; (b) (6), (b) (7)(C)

(b) (6), (b) (7)(C) @denvergov.org; (b) (6), (b) (7)(C)

(b) (6), (b) (7)(C) @denvergov.org>

Subject: RE: PR Bonds - CORA Request - DPD

Hi Cmdr,

Is there any documentation for the partnership between DPD and the Feds/USADA's? DPD just got a CORA request regarding a recent article published by CBS Denver4 about Chief Pazen making statements that the rise in crime is due to PR/low bonds.

- Regarding item #4 in the CORA request. (b) (6), (b) (7) or (b) (6), (b) (7)(C) are either of you aware of any documents about a partnership between DPD and federal agents? An MOU or anything else indicating a formal or informal agreement?

If there is any MOU or any other documentation, can you please send it to me? They are looking to have this by next week so anything you have by then would be great.

Thanks!

(b) (6), (b) (7)(C) | Crime Analyst

Denver Police Department Special Operations Response Team (SORT) | City and County of Denver

Pronouns | She/Her/Hers

p: (b) (6), (b) (7)(C) c: (b) (6), (b) (7)(C) | @denvergov.org

In office: Monday, Tuesday, and Thursday

Remote: Wednesday and Friday

<image002.jpg>

From: (b) (6), (b) (7)(C)

(b) (6), (b) (7)(C) @denvergov.org>

Sent: Thursday, August 05, 2021 1:21 PM

To: (b) (6), (b) (7)(C)

(b) (6), (b) (7)(C) @denvergov.org>

Subject: FW: PR Bonds - CORA Request - DPD

Per Teams chat. This is my original email and attachments and I'll send you (b) (6), (b) (7)(C) next.

Thank you!

(b) (6), (b) (7)(C)

In office/District 6: Monday and Thursday

In office/HQ 412: Tuesday

Remote: Wednesday and Friday

<image003.png>

(b) (6), (b) (7)(C) | Data Analysis Unit

Denver Police Dept | City and County of Denver

Pronouns | She/Her/Hers

p: (b) (6), (b) (7)(C) (b) (6), (b) (7)(C)@denvergov.org

CONNECT WITH US | [311](#) | [pocketgov.com](#) | [denvergov.org](#) | [Denver 8 TV](#) | [Facebook](#)

From: (b) (6), (b) (7)(C)
Sent: Thursday, August 5, 2021 12:07 PM
To: (b) (6), (b) (7)(C)
(b) (6), (b) (7)(C)@denvergov.org; (b) (6), (b) (7)(C)
(b) (6), (b) (7)(C)@denvergov.org; (b) (6), (b) (7)(C)
(b) (6), (b) (7)(C)@denvergov.org; (b) (6), (b) (7)(C)
(b) (6), (b) (7)(C)@denvergov.org; (b) (6), (b) (7)(C)
(b) (6), (b) (7)(C)@denvergov.org
Cc: (b) (6), (b) (7)(C)@denvergov.org
Subject: PR Bonds - CORA Request - DPD

Hi All,

Looping all of 412 and (b) (6), (b) (7) and (b) (6), (b) (7)(C) in. ACLU made a CORA request regarding [this article](#) (attached). I just got off a call with (b) (6), (b) (7)(C) who is making a response plan. Below are some things she needs from us. I'm also adding her on this email so that we can have one place for everything, and so she can chime in on anything I may have missed. There is a plan for another meeting next week, but I wanted to get this out to everyone in the meantime.

- Information and data used for Chief Pazen's talking points
 - a. (b) (6), (b) (7)(C) sent her analysis and methodology on bond and recidivism to me this AM (attached), but can you please send the data?
 - b. (b) (6), (b) (7) can you respond to this email with your data on homicide suspects and their bond/supervision status?
 - c. Attached is the info on POWPO arrest and seized guns that came out of 412
- Regarding item #2, we need to look into what kind of data might be available that can provide time stamps in Versadex
- Regarding item #4 in the CORA request. (b) (6), (b) (7) or (b) (6), (b) (7)(C) are either of you aware of any documents about a partnership between DPD and federal agents? An MOU or anything else indicating a formal or informal agreement?
- As part the larger conversation in general, (b) (6), (b) (7)(C) is asking for data on people arrested for homicide, FAST cases, and motor vehicle theft from Jan 1, 2018. Craig, when was FAST formed, early 2020? This might present an issue on that piece.

(b) (6) please let us know if there is anything else. I am in D6 meetings for a good portion of the afternoon and off tomorrow, which is why I wanted us all to have the same info in one place. I'll keep everyone posted on whatever progress I can make today.

Thanks,



In office/District 6: Monday and Thursday

In office/HQ 412: Tuesday

Remote: Wednesday and Friday

<image003.png>

(b) (6), (b) (7)(C) | Data Analysis Unit

Denver Police Dept | City and County of Denver

Pronouns | She/Her/Hers

p: (b) (6), (b) (7)(C) | (b) (6), (b) (7)(C)@denvergov.org

CONNECT WITH US | [311](#) | [pocketgov.com](#) | [denvergov.org](#) | [Denver 8 TV](#) | [Facebook](#)

MEMORANDUM OF UNDERSTANDING

BETWEEN

THE BUREAU OF ALCOHOL, TOBACCO, FIREARMS AND EXPLOSIVES (ATF),

And

DENVER POLICE DEPARTMENT

This Memorandum of Understanding (“MOU”) is entered into by and between the Bureau of Alcohol, Tobacco, Firearms and Explosives (“ATF”) and Denver, Colorado Police Department (“participating agency”) as it relates to the Regional Anti Violence Enforcement Network Task Force (herein referred to as the “RAVEN”).

BACKGROUND

The Regional Anti Violence Enforcement Network (“RAVEN”) fills a strong need in Colorado for a proactive, intelligence-based targeting of criminal offenders in the Judicial District of Colorado. RAVEN will produce timely, precise, and objective intelligence data (via NIBIN and crime gun tracing) to focus the efforts of federal, state and local law enforcement, forensic, and prosecutorial resources on the most violent offenders in the Denver Metropolitan area. Denver, Aurora and Lakewood are currently designated as the sites of a Project Safe Neighborhood (“PSN”) intervention because their combined violent crime totals are the highest in the state and their shared border lends itself to collaborative investigations. The RAVEN concept was selected as the key intervention because of its ability to identify Colorado’s most violent offenders in a collaborative manner.

AUTHORITIES

The authority to investigate and enforce offenses under provisions of this MOU are found at 28 U.S.C. § 599A, 28 C.F.R. §§ 0.130, 0.131, and 18 U.S.C. § 3051.

PURPOSE

The RAVEN Task Force will perform the activities and duties described below:

- a. Investigate firearms trafficking
- b. Investigate firearms related violent crime
- c. Gather and report intelligence data relating to trafficking in firearms
- d. Conduct undercover operations where appropriate and engage in other traditional methods of investigation in order that the RAVEN Task Force's activities will result in

effective prosecution before the courts of the United States and the State of Colorado.

MEASUREMENT OF SUCCESS

The success of the RAVEN will be measured by the participating agencies willingness to share certain information, such as crime statistics and NIBIN results. Success of the RAVEN will involve increased multiple NIBIN matches, a higher clearance rates for violent crimes, increased crime gun interdiction, reducing violent crime rates involving firearms, increased effective deployment of law enforcement resources, and increased prosecution of violent gun crime.

PHYSICAL LOCATION

Officers/troopers/agents/investigators assigned to the RAVEN by their employer will be located at the covert RAVEN office in Aurora, Colorado.

SUPERVISION AND CONTROL

The day-to-day supervision and administrative control of officers/investigators/agents/other employees (“participants”) assigned to the RAVEN will be the mutual responsibility of the participants, the ATF Special Agent in Charge or his/her designee and the Aurora Police Department Chief of Police having operational control over all operations related to the RAVEN.

Each TFO shall remain subject to their respective agencies' policies and shall report to their respective agencies regarding matters unrelated to this agreement/task force. With regard to matters related to the RAVEN Task Force, TFOs will be subject to Federal law and Department of Justice (DOJ) and ATF orders, regulations and policy, including those related to standards of conduct, sexual harassment, equal opportunity issues and Federal disclosure laws.

Failure to comply with this paragraph could result in a TFO’s dismissal from the Task Force.

PERSONNEL, RESOURCES AND SUPERVISION

To accomplish the objectives of the RAVEN Task Force, ATF will assign a group of Special Agents and a Group Supervisor to the RAVEN Task Force. ATF will also, subject to the availability of funds, provide necessary funds and equipment to support the activities of the ATF Special Agents and officers assigned to the RAVEN Task Force. This support may include: overtime monies, JLEO vehicles, office space, office supplies, travel funds, funds for the purchase of evidence and information, investigative equipment, training, and other support items.

Each participating agency agrees to make available to their assigned RAVEN Task Force members any equipment ordinarily assigned for use by that agency. In the event ATF supplies equipment (which may include vehicles, weapons or radios), TFOs must abide by any applicable ATF property orders or policy and may be required to enter into a separate agreement for their use.

To accomplish the objectives of the RAVEN Task Force, the Denver Police Department agrees to detail a group of fulltime TFOs and/or Special Deputies and a supervisor(s) with the rank of sergeant to the RAVEN Task Force for a period of not less than two (2) years.

All TFOs shall qualify with their respective firearms by complying with ATF's Firearms and Weapons Policy.

SECURITY CLEARANCES

All TFOs and Special Deputies will undergo a security clearance and background investigation, and ATF shall bear the costs associated with those investigations. TFOs and Special Deputies must not be the subject of any ongoing investigation by their department or any other law enforcement agency, and past behavior or punishment, disciplinary, punitive or otherwise, may disqualify one from eligibility to join the RAVEN Task Force. ATF has final authority as to the suitability of TFOs and Special Deputies for inclusion on the RAVEN Task Force.

DEPUTATIONS

ATF, as the sponsoring Federal law enforcement agency, may request at its sole discretion that the participating agency's TFOs and Special Deputies be deputized by the U.S. Marshals Service to extend their jurisdiction, to include applying for and executing Federal search and arrest warrants, and requesting and executing Federal grand jury subpoenas for records and evidence involving violations of Federal laws. Such requests will be made on an individual basis as determined by ATF.

A TFO and Special Deputy will not be granted Department of Justice legal representation if named as a defendant in a private-capacity lawsuit alleging constitutional violations unless all deputation paperwork has been completed prior to the event(s) at issue in the lawsuit.

The participating agencies agree that any Federal authority that may be conferred by a deputation is limited to activities supervised by ATF and will terminate when this MOU is terminated or when the deputized TFOs and/or Special Deputies leave the RAVEN Task Force, or at the discretion of ATF.

ASSIGNMENTS, REPORTS AND INFORMATION SHARING

An ATF supervisor or designee will be empowered with designated oversight for investigative and personnel matters related to the RAVEN Task Force and will be responsible for opening, monitoring, directing and closing RAVEN Task Force federal investigations in accordance with ATF policy and the applicable United States Attorney General's Guidelines.

Assignments will be based on, but not limited to, experience, training and performance, in addition to the discretion of the ATF supervisor.

All investigative reports will be prepared utilizing ATF's investigative case management system, (N-Force) utilizing ATF case report numbers. The participating agency will share investigative

reports, findings, intelligence, etc., in furtherance of the mission of this agreement, to the fullest extent allowed by law. For the purposes of uniformity, there will be no duplication of reports, but rather a single report prepared by a designated individual which can be duplicated as necessary. Every effort should be made to document investigative activity on ATF Reports of Investigation (ROI), unless otherwise agreed to by ATF and the participating agency(ies). This section does not preclude the necessity of individual TFOs and Special Deputies to complete forms required by their employing agency.

Information will be freely shared among the TFOs, Special Deputies and ATF personnel with the understanding that all investigative information will be kept strictly confidential and will only be used in furtherance of criminal investigations. No information gathered during the course of the RAVEN Task Force, to include informal communications between TFOs, Special Deputies and ATF personnel, may be disseminated to any third party, non-task force member by any task force member without the express permission of the ATF Special Agent in Charge or his/her designee.

Any public requests for access to the records or any disclosures of information obtained by task force members during RAVEN Task Force federal investigations will be handled in accordance with applicable statutes, regulations, and policies pursuant to the Freedom of Information Act and the Privacy Act and other applicable federal and/or state statutes and regulations.

INVESTIGATIVE METHODS

The parties agree to utilize Federal standards pertaining to evidence handling and electronic surveillance activities to the greatest extent possible. However, in situations where state or local laws are more restrictive than comparable Federal law, investigative methods employed by state and local law enforcement agencies shall conform to those requirements, pending a decision as to a venue for prosecution.

The use of other investigative methods (search warrants, interceptions of oral communications, etc.) and reporting procedures in connection therewith will be consistent with the policy and procedures of ATF. All Task Force operations will be conducted and reviewed in accordance with applicable ATF and Department of Justice policy and guidelines.

None of the parties to this MOU will knowingly seek investigations under this MOU that would cause a conflict with any ongoing investigation of an agency not party to this MOU. It is incumbent upon each participating agency to notify its personnel regarding the Task Force's areas of concern and jurisdiction. All law enforcement actions will be coordinated and cooperatively carried out by all parties to this MOU.

INFORMANTS

ATF guidelines and policy regarding the operation of informants and cooperating witnesses will apply to all ATF informants and cooperating witnesses directed by TFOs and Special Deputies.

Informants developed by TFOs and Special Deputies may be registered as informants of their respective agencies for administrative purposes and handling. The policies and procedures of the participating agency with regard to handling informants will apply to all informants that the participating agency registers. In addition, it will be incumbent upon the registering participating agency to maintain a file with respect to the performance of all informants or witnesses it registers. All information obtained from an informant and relevant to matters within the jurisdiction of this MOU will be shared with all parties to this MOU. The registering agency will pay all reasonable and necessary informant expenses for each informant that a participating agency registers.

DECONFLICTION

Each participating agency agrees that the deconfliction process requires the sharing of certain operational information with the RAVEN Task Force, which, if disclosed to unauthorized persons, could endanger law enforcement personnel and the public. As a result of this concern, each participating agency agrees to adopt security measures set forth herein:

- a. Each participating agency will assign primary and secondary points of contact.
- b. Each participating agency agrees to keep its points of contact list updated.

The points of contact for the RAVEN Task Force are:

ATF: Group Supervisor (b) (6), (b) (7)(C)

Aurora Police Department: Lieutenant (b) (6), (b) (7)(C)

EVIDENCE

Evidence will be maintained by the lead agency having jurisdiction in the court system intended for prosecution. Evidence generated from investigations initiated by a TFO or ATF special agent intended for Federal prosecution will be placed in the ATF designated vault, using the procedures found in ATF orders.

All firearms seized by a TFO must be submitted for fingerprint analysis and for a National Integrated Ballistic Information Network (NIBIN) examination. Once all analyses are completed, all firearms seized under Federal law shall be placed into the ATF designated vault for proper storage. All firearms information/descriptions taken into ATF custody must be submitted to ATF's National Tracing Center.

JURISDICTION/PROSECUTIONS

Cases will be reviewed by the ATF Special Agent in Charge or his/her designee in consultation with the participating agency and the United States Attorney's Office and appropriate State's attorney offices, to determine whether cases will be referred for prosecution to the U.S. Attorney's Office or to the relevant State's attorney's office. This determination will be based upon which

level of prosecution will best serve the interests of justice and the greatest overall benefit to the public. Any question that arises pertaining to prosecution will be resolved through discussion among the investigative agencies and prosecuting entities having an interest in the matter.

In the event that a state or local matter is developed that is outside the jurisdiction of ATF or it is decided that a case will be prosecuted on the state or local level, ATF will provide all relevant information to state and local authorities, subject to Federal law. Whether to continue investigation of state and local crimes is at the sole discretion of the state or local participating agency.

USE OF FORCE

All fulltime TFOs and Special Deputies will comply with ATF and the Department of Justice's (DOJ's) Use of Force orders and policies. TFOs and Special Deputies must be briefed on ATF's and DOJ's Use of Force policy by an ATF official, and will be provided with a copy of such policy.

BODY WORN CAMERAS AND TASK FORCE OFFICERS

In accordance with DOJ policy, dated October 29, 2020, Body Worn Cameras (BWCs) may be worn by TFOs and Special Deputies operating on a Federal Task Force when their parent agency mandates their use by personnel assigned to the task force. In such cases, the parent agency must formally request to participate in the TFO BWC program and, upon approval, shall comply with all DOJ and ATF policies, and the required procedures, documentation, and reporting while participating on the task force.

MEDIA

Media relations will be handled by ATF, Aurora Police Department and the U.S. Attorney's Office's public information officers in coordination with each participating agency. Information for press releases will be reviewed and mutually agreed upon by all participating agencies, who will take part in press conferences. Assigned personnel will be informed not to give statements to the media concerning any ongoing investigation or prosecution under this MOU without the concurrence of the other participants and, when appropriate, the relevant prosecutor's office.

All personnel from the participating agencies shall strictly adhere to the requirements of Title 26, United States Code, § 6103. Disclosure of tax return information and tax information acquired during the course of investigations involving National Firearms Act (NFA) firearms as defined in 26 U.S.C., Chapter 53 shall not be made except as provided by law.

SALARY/OVERTIME COMPENSATION

During the period of the MOU, participating agencies will provide for the salary and employment benefits of their respective employees. All participating agencies will retain control over their employees' work hours, including the approval of overtime.

ATF may have funds available to reimburse overtime to the State and Local TFO's agency, subject to the guidelines of the Department of Justice Asset Forfeiture Fund. This funding would be

available under the terms of a memorandum of agreement (MOA) established pursuant to the provisions of 28 U.S.C. section 524. The participating agency agrees to abide by the applicable Federal law and policy with regard to the payment of overtime from the Department of Justice Asset Forfeiture Fund. The participating agency must be recognized under State law as a law enforcement agency and their officers/ troopers/investigators as sworn law enforcement officers. If required or requested, the participating agency shall be responsible for demonstrating to the Department of Justice that its personnel are law enforcement officers for the purpose of overtime payment from the Department of Justice Asset Forfeiture Fund. **This MOU is not a funding document.**

In accordance with these provisions and any MOA on asset forfeiture, the ATF Special Agent in Charge or designee shall be responsible for certifying reimbursement requests for overtime expenses incurred as a result of this agreement.

AUDIT INFORMATION

Operations under this MOU are subject to audit by ATF, the Department of Justice's Office of the Inspector General, the Government Accountability Office, and other Government-designated auditors. Participating agencies agree to permit such audits and to maintain all records relating to Department of Justice Asset Forfeiture Fund payments for expenses either incurred during the course of this Task Force or for a period of not less than three (3) years and, if an audit is being conducted, until such time that the audit is officially completed, whichever is greater.

FORFEITURES/SEIZURES

All assets seized for administrative forfeiture will be seized and forfeited in compliance with the rules and regulations set forth by the U.S. Department of Justice Asset Forfeiture guidelines. When the size or composition of the item(s) seized make it impossible for ATF to store it, any of the participating agencies having the storage facilities to handle the seized property agree to store the property at no charge and to maintain the property in the same condition as when it was first taken into custody. The agency storing said seized property agrees not to dispose of the property until authorized to do so by ATF.

The MOU provides that proceeds from forfeitures will be shared, with sharing percentages based upon the U.S. Department of Justice Asset Forfeiture policies on equitable sharing of assets, such as determining the level of involvement by each participating agency. Task Force assets seized through administrative forfeiture will be distributed in equitable amounts based upon the number of full-time persons committed by each participating agency. Should it become impossible to separate the assets into equal shares, it will be the responsibility of all the participating agencies to come to an equitable decision. If this process fails and an impasse results, ATF will become the final arbitrator of the distributive shares for the participating agencies

DISPUTE RESOLUTION

In cases of overlapping jurisdiction, the participating agencies agree to work in concert to achieve the Task Force's goals and objectives. The parties to this MOU agree to attempt to resolve any disputes regarding jurisdiction, case assignments and workload at the lowest level possible.

LIABILITY

ATF acknowledges that the United States is liable for the wrongful or negligent acts or omissions of its officers and employees, including TFOs, while on duty and acting within the scope of their federal employment, to the extent permitted by the Federal Tort Claims Act.

Claims against the United States for injury or loss of property, personal injury, or death arising or resulting from the negligent or wrongful act or omission of any Federal employee while acting within the scope of his or her office or employment are governed by the Federal Tort Claims Act, 28 U.S.C. sections 1346(b), 2672-2680 (unless the claim arises from a violation of the Constitution of the United States, or a violation of a statute of the United States under which other recovery is authorized).

Except as otherwise provided, the parties agree to be solely responsible for the negligent or wrongful acts or omissions of their respective employees and will not seek financial contributions from the other for such acts or omissions. Legal representation by the United States is determined by the United States Department of Justice on a case-by-case basis. ATF cannot guarantee the United States will provide legal representation to any State or local law enforcement officer.

Liability for any negligent or willful acts of any agent or officer undertaken outside the terms of this MOU will be the sole responsibility of the respective agent or officer and agency involved.

DURATION

This MOU is effective with the signatures of all parties and terminates at the close of business on September 30, 2026.

This MOU supersedes previously signed MOUs and shall remain in effect until the aforementioned expiration date or until it is terminated in writing (to include electronic mail and facsimile), whichever comes first. All participating agencies agree that no agency shall withdraw from the Task Force without providing ninety (90) days written notice to other participating agencies. If any participating agency withdraws from the Task Force prior to its termination, the remaining participating agencies shall determine the distributive share of assets for the withdrawing agency, in accordance with Department of Justice guidelines and directives.

The MOU shall be deemed terminated at the time all participating agencies withdraw and ATF elects not to replace such members, or in the event ATF unilaterally terminates the MOU upon 90 days written notice to all the remaining participating agencies.

MODIFICATIONS

This agreement may be modified at any time by written consent of all participating agencies. Modifications shall have no force and effect unless such modifications are reduced to writing and signed by an authorized representative of each participating agency.

SIGNATURES

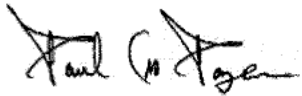

07-30-2021

Paul Pazen Date
Title: Chief of Police
Department: Denver, Colorado Police Department

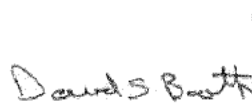

Digitally signed
by DAVID BOOTH
Date: 2021.07.30
12:23:44 -06'00'

David Booth Date
Title: Special Agent in Charge, ATF
Field Division: Denver

To: (b) (6), (b) (7)(C)
Cc: (b) (6), (b) (7)(C); (b) (6), (b) (7)(C)
From: (b) (6), (b) (7)(C)
Sent: Wed 8/11/2021 12:51:10 AM
Subject: PIA - Axon Evidence
ATF Axon Evidence PIA_08-10-2021.docx

The attached is a re-write of the PIA for Axon – OPCL has made some changes to how they want the information described.

This is a good example of what they want to see now
(<https://www.justice.gov/opcl/page/file/1412716/download>).

V/ (b) (6)

(b) (5)

(b) (5), (b) (6)

(b) (5)

(b) (5)

(b) (5)

(b) (5)

(b) (5)

(b) (5)

(b) (5)

(b) (5)

(b) (5)

(b) (5)

(b) (5)

(b) (5)

(b) (5)

(b) (5)

(b) (5)

To: (b) (6), (b) (7)(C)
Cc: (b) (6), (b) (7)(C)
From: (b) (6), (b) (7)(C)
Sent: Tue 6/29/2021 1:35:07 PM
Subject: FW: ATF Senate CJS FY 2022 Get Backs - 6.28.21 (b) (6), (b) (7)(C) Edits-db
ATF Senate CJS FY 2022 Get Backs - 6.28.21 (b) (6), (b) (7)(C) Edits-(b) (6), (b) (7)(C).docx

Hi (b) (6), (b) (7)(C)

You may have already seen this but I wanted to make sure you were aware of ATF's proposed response to the Senate CJS on the BWC initiative. It's on pages 7 & 8 but I also copied below for ease of review.

Thanks.

(b) (6), (b) (7)(C)

1. **Body Worn Cameras (BWC) – How many ATF TFOs use BWC? What are we doing in Phase I and what is the total cost? Estimate for all agents in the FY23 proposal. Number of FOIA employees, lawyers, etc.**

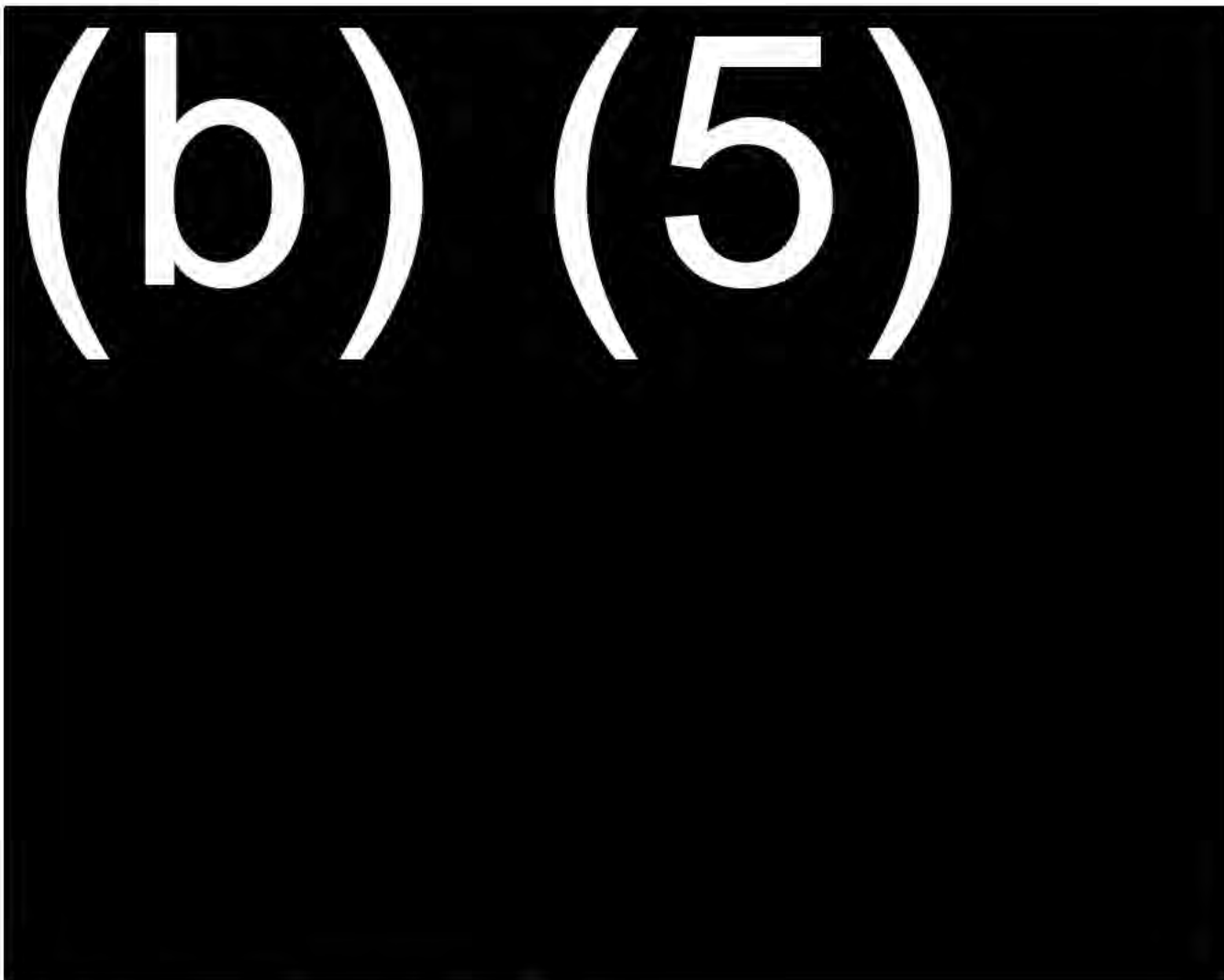

From: Board, Daniel L., Jr. (b) (6), (b) (7)(C)
Sent: Monday, June 28, 2021 5:45 PM

To: (b) (6), (b) (7)(C) (b) (6), (b) (7)(C) (b) (6), (b) (7)(C)
(b) (6), (b) (7)(C) (b) (6), (b) (7)(C)
Cc: (b) (6), (b) (7)(C)
Subject: ATF Senate CJS FY 2022 Get Backs - 6.28.21 CG Edits-db

A few comments and suggested changes.

Db

(b) (6), (b) (7)(C)

Once this has been finalized, please consider it cleared to transmit back to OM.
Thank you both for the review

danny

(b) (5)

(b) (5)

(b) (5)

(b) (5)

(b) (5)

(b) (5)

(b) (5)

(b) (5)

(b) (5)

(b) (5)

To: (b) (6), (b) (7)(C) (b) (6), (b) (7)(C)
Cc: Vanderplow, Paul (b) (6), (b) (7)(C) (b) (6), (b) (7)(C) (b) (6), (b) (7)(C)
(b) (6), (b) (7)(C) (b) (6), (b) (7)(C) (b) (6), (b) (7)(C)
(b) (6), (b) (7)(C) (b) (6), (b) (7)(C) (b) (6), (b) (7)(C) (b) (6), (b) (7)(C)
From: (b) (6), (b) (7)(C)
Sent: Tue 8/31/2021 4:29:04 PM
Subject: Body-Worn Camera supporting documents
[ATF Policy BWC 8_23_21.docx](#)
[Axon ATF BWC Training Presentation.pdf](#)
[ATF - DEM - BWC - SOP - 21-08-31.docx](#)

I have attached the following body-worn camera supporting documentation for dissemination to your division.

- ATF Body-Worn Camera Policy
- Axon Training PowerPoint Presentation
- ATF Digital Evidence Management Standard Operating Procedures (SOP)

Regarding the SOP's please note the first 37 pages pertain to the **TFO BWC Program**, the ATF BWC program SOP's begin on page 38.

NOTE: These documents are still provisional and may change over the course of phase I.

In addition, your division personnel should begin to see the web clip survey on their phones. Unfortunately, OST informed me yesterday, due to inaccurate/incomplete Active Directories for the divisions they were required to send the web clip division-wide, therefore please notify the non-1811's in your division this web clip is for the BWC survey only.

Topics of discussion:

During the training, several topics were introduced that required further clarification. Below are those topics and the resulting responses:

1. How do I document BWC activations when I don't have an active ATF case?

Per Field Operations, each activation of a BWC will require documentation in an "actual" case in NForce, therefore if you are assisting a partner agency i.e. the USMS on a pre-planned arrest or search warrant, or while doing so anticipate an interaction with the public that could lead to use of force, you will be required to open a case and document those in an ROI and under the property tab for each activation.

2. Can I store other digital evidence in Evidence.com?

Yes, an agent may store other digital evidence in Evidence.com, however **no electronic surveillance media** can be stored in Evidence.com.

3. If an agent is working with the FBI JTTF in the National Security Group, BWC's will not be activated during pre-planned arrest or search warrants.

4. Agents will wear the ballistic vests while conducting enforcement operations, however in the rare circumstances that require the covert vests, BWC wing clip mounts have been provided.

Additional Mounts:

Detroit FD should be receiving the single molle mounts, web clip mounts, and Flex 2 helmet mounts today. Phoenix will be receiving their web clip mounts today, the single molle mounts will be provided at a later date.

Finally, please notify your Division Sunflower point of contact you will be receiving a request to accept the BWC equipment in Sunflower.

(b) (6), (b) (7)(C)

Alcohol, Tobacco, Firearms and Explosives

16009 N. 81st Street, Suite 100

Scottsdale, AZ 85260

Special Agent Project Officer-Digital Evidence Management

Technical Project Office

Special Operations Division

(b) (6), (b) (7)(C)

CONFIDENTIALITY NOTICE: E-mail may contain confidential information that is legally privileged. Do not read this e-mail if you are not the intended recipient.

This e-mail transmission, and any documents, files or previous e-mail messages attached to it may contain confidential information that is legally privileged. If you are not the intended recipient, or a person responsible for delivering it to the intended recipient, you are hereby notified that any disclosure, copying, distribution or use of any of the information contained in or attached to this transmission is **STRICTLY PROHIBITED**. If you have received this transmission in error, please immediately notify us by reply e-mail, by forwarding this to **(b) (6), (b) (7)(C)** or by telephone at **(b) (6), (b) (7)(C)** and destroy the original transmission and its attachments without reading or saving in any manner. Thank you.

(b) (5)

(b) (5)

(b) (5)

(b) (5)

(b) (5)

(b) (5)

(b) (5)

(b) (5)



US BUREAU OF ALCOHOL, TOBACCO, FIREARMS AND EXPLOSIVES

Agent, Group Supervisor,
and SAC/Admin/Trainer Training

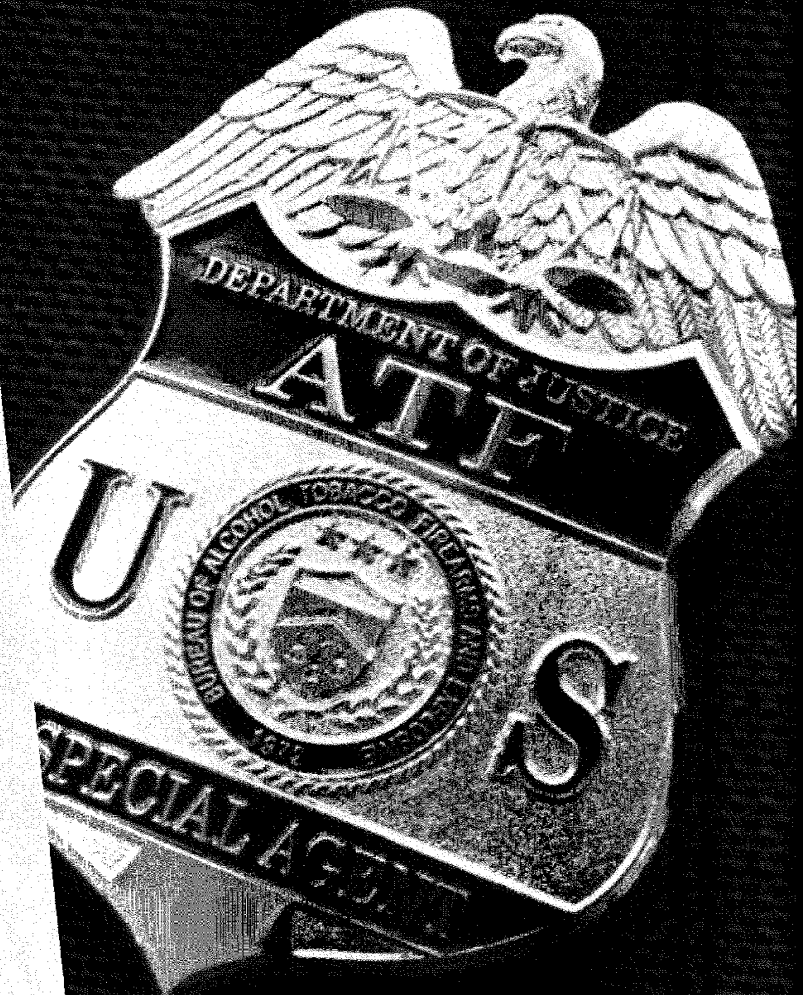

NOTICE – INTERNAL USE ONLY

These training materials are copyrighted, and all rights are reserved by Axon Enterprise, Inc.

These training materials are provided by Axon to our product customers for their internal, non-commercial training purposes only.

Further reproduction, distribution, transmission, display, or broadcast of these materials is prohibited without the prior written permission of Axon Enterprise, Inc.

AGENDA

AXON BODY 3 (AB3) OVERVIEW

AXON FLEX 2 (AF2) OVERVIEW

AXON RESPOND

MOUNTS

AXON DOCK

AXON CAPTURE/CITIZEN

AXON EVIDENCE

BREAK

GROUP SUPERVISOR FUNCTIONS

BREAK

SAC, ADMIN AND TRAINER FUNCTIONS



ATF BWC Workflow

Retrieve BWC From Dock



Mount BWC

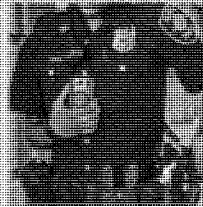

Record BWC Video

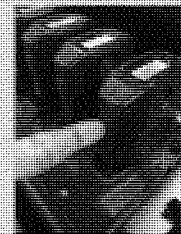

Access Axon Evidence to Review Evidence, Upload Evidence, Add Metadata, Redact Evidence or Share Evidence

Dock BWC

Connect to View XL or Sync to Add Metadata or Priority Upload



WELCOME

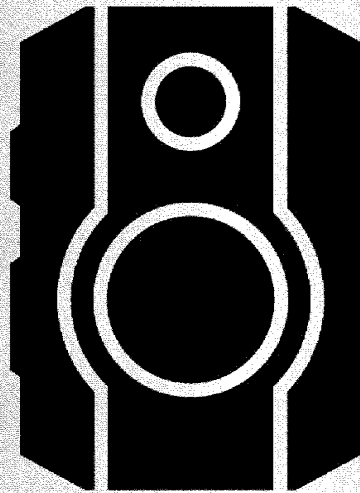

AXON BODY 3



■ AXON APP DEFINITIONS

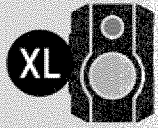

View XL SYNC
(Standalone Software)

**Video playback, metadata entry, evidence upload,
and AB3 / AF2 settings**



Axon Evidence

Cloud based Digital Evidence Management System (DEMS)

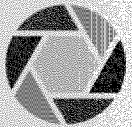

Capture
(Mobile App)

**Video, audio, and image capture from mobile device and upload
directly to Axon Evidence**

SYNC
(Standalone Software)

**Video playback, metadata entry, evidence upload, and AB3 /
AF2 settings**

AB3 OVERVIEW

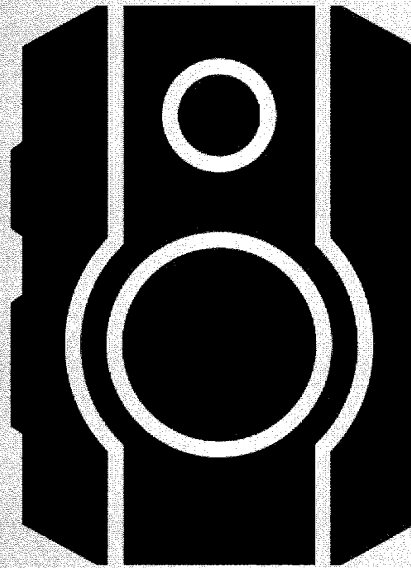

AB3 OVERVIEW

- 12+ hour battery life under normal use
- 30 frames per second
- 146° diagonal field of view camera lens
- IP67 rating
- 720H HD
- Embedded GPS
- LTE Connectivity
- LCD Display
- Multicam Playback
- Axon Respond & Respond+ capability



CLEANING THE AB3



- Use a soft, damp cloth to clean the surface of the AB3. Do not use harsh cleaners or solvents. You may moisten the cloth with isopropyl alcohol
- Do not immerse the AB3 in water or cleaning solutions
- If the AB3 camera lens becomes dirty, use a lens blower brush to clean it and then wipe it with a soft cloth if necessary
- If the AB3 camera display becomes dirty, clean the display with soapy water and then dry with a soft cloth
- Do not use ammonia-based or similar type window cleaners on the camera lens or camera display
- Do not place the lens under running water or apply jets of water
- Ensure the AB3 microphone openings are clean and clear of any debris

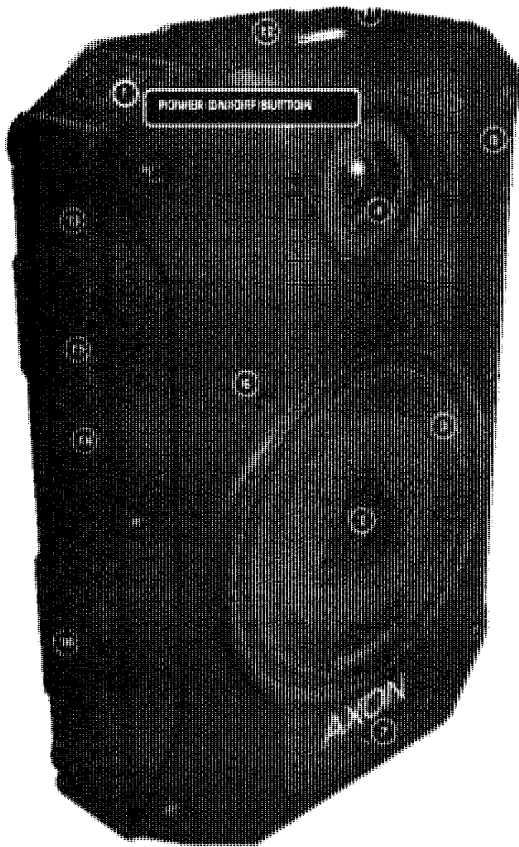

AB3 | POWER BUTTON



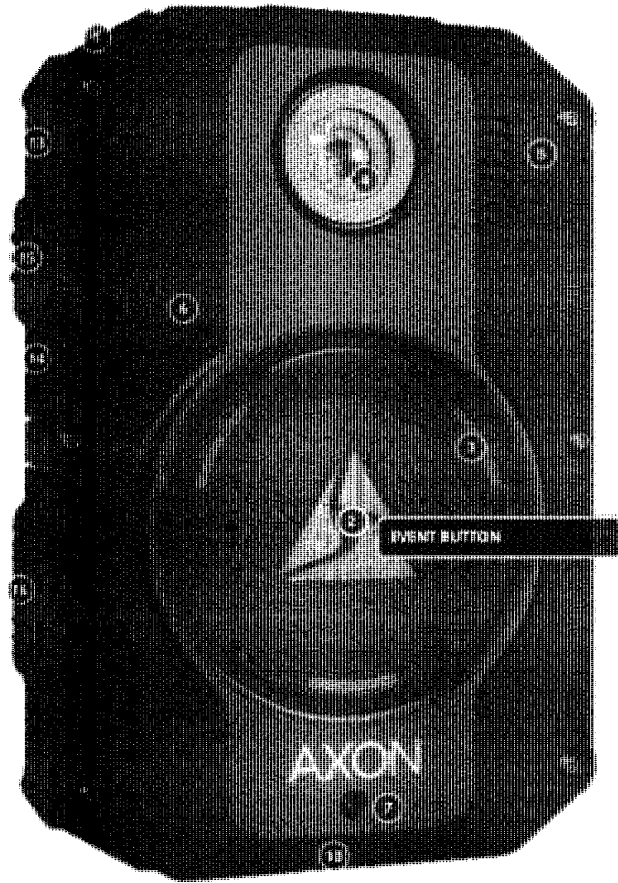

AB3 | EVENT BUTTON





AB3 | TRIAD LED



AB3 | LENS



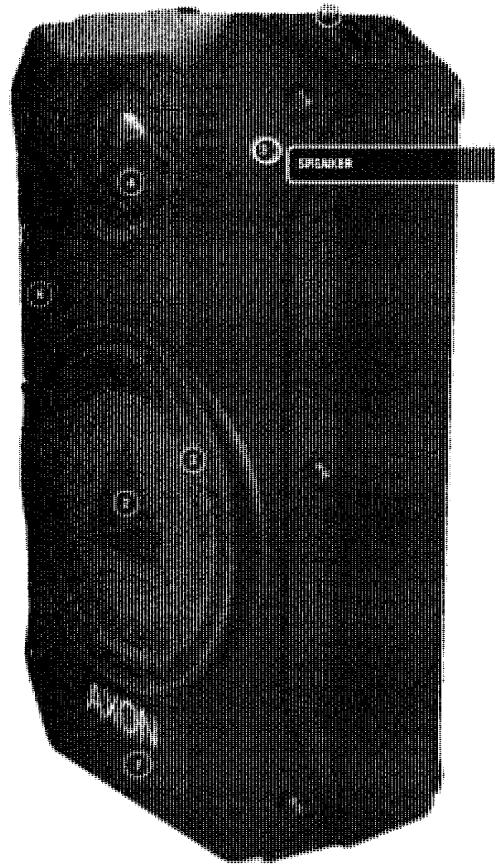

AB3 | SPEAKER





AB3 | MICROPHONES



6

MICROPHONE 3/4

7

5

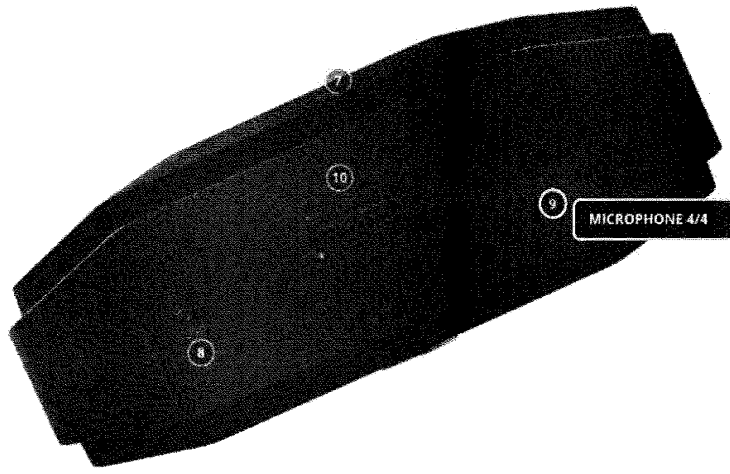

7

10

9

MICROPHONE 4/4

8



AB3 | MICROPHONES

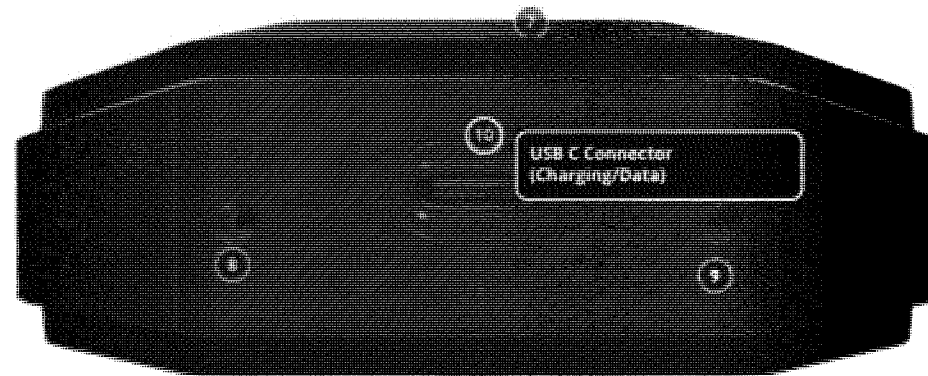

AB3 | USB C CONNECTOR

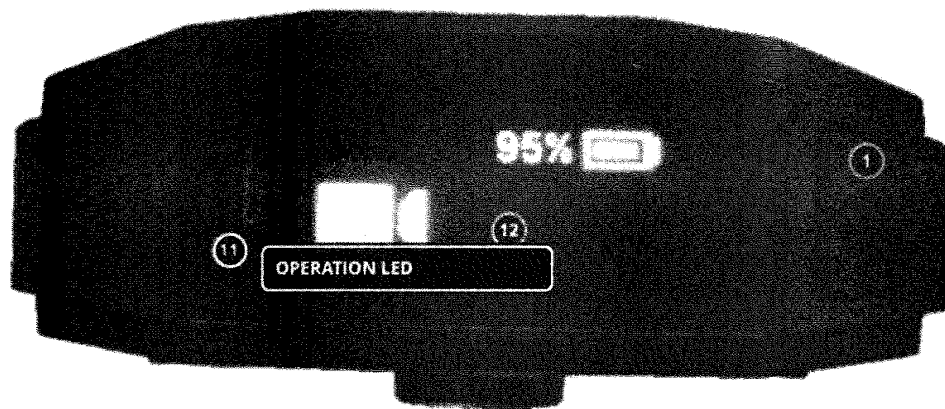

AB3 | OPERATION LED

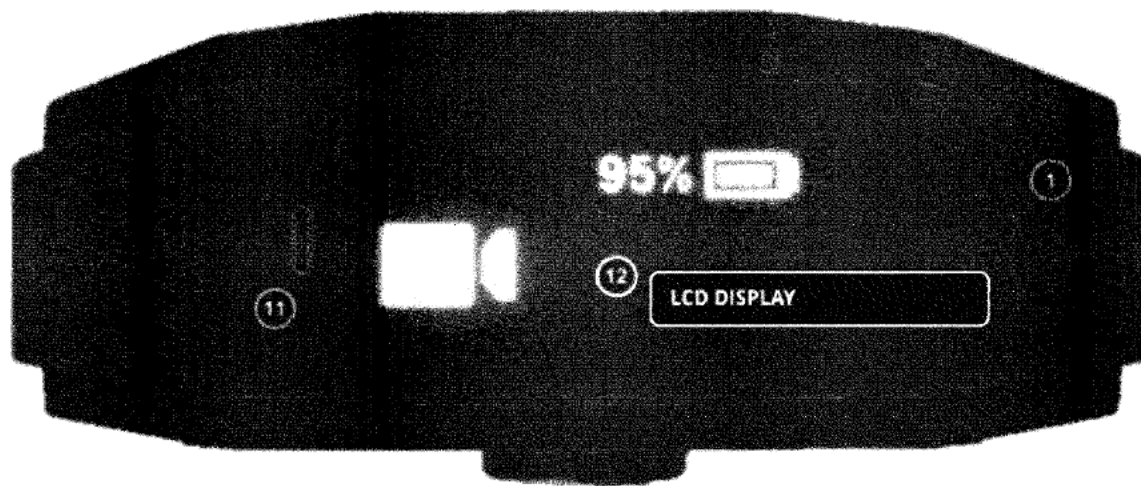

A83 | LCD DISPLAY

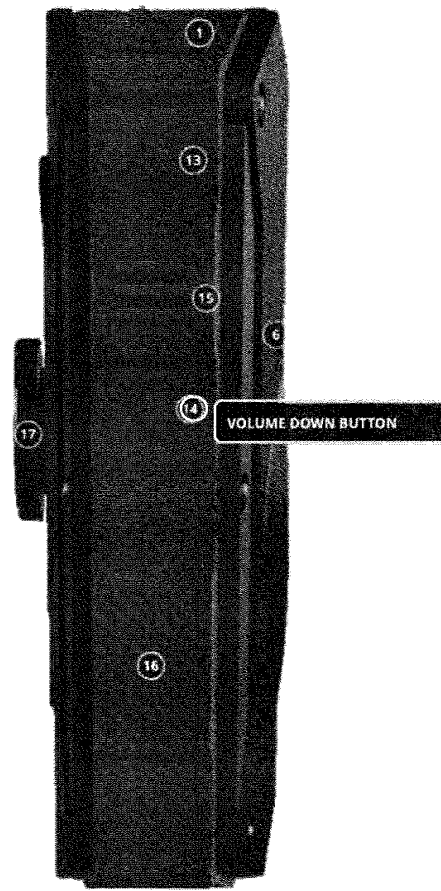
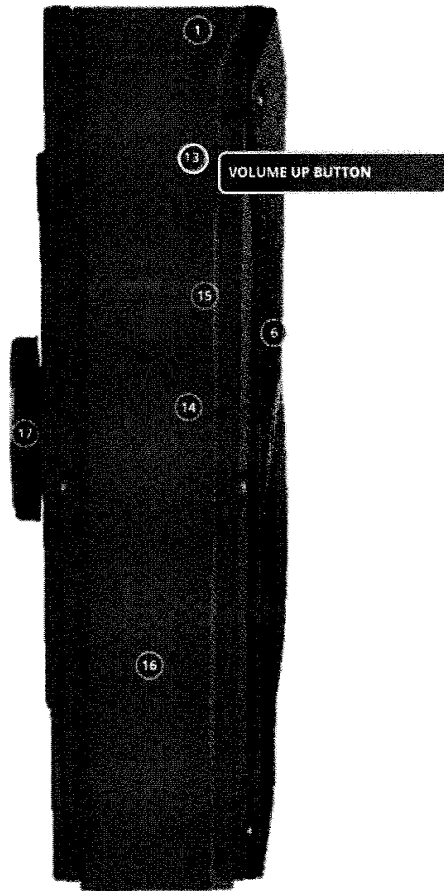

AB3 | VOLUME BUTTONS

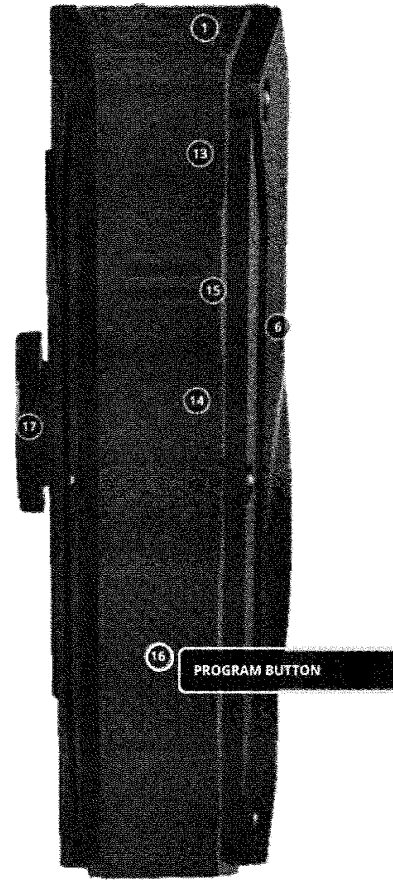
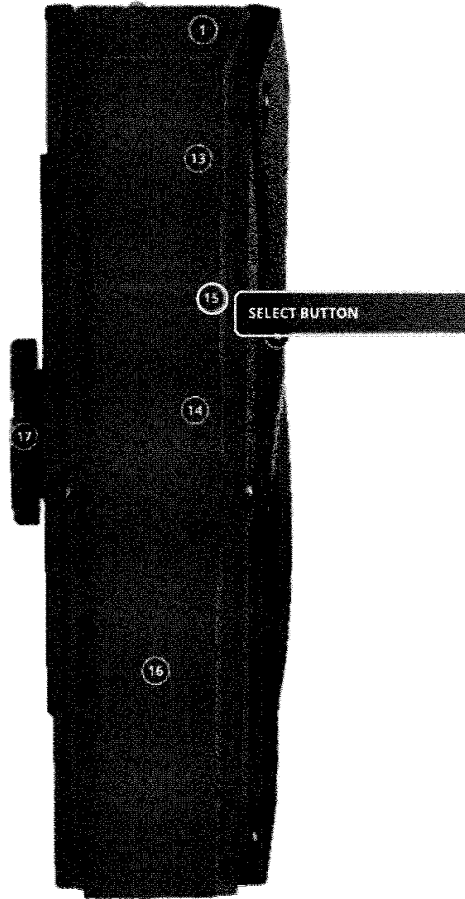

AB3 | SELECT + PROGRAM BUTTONS

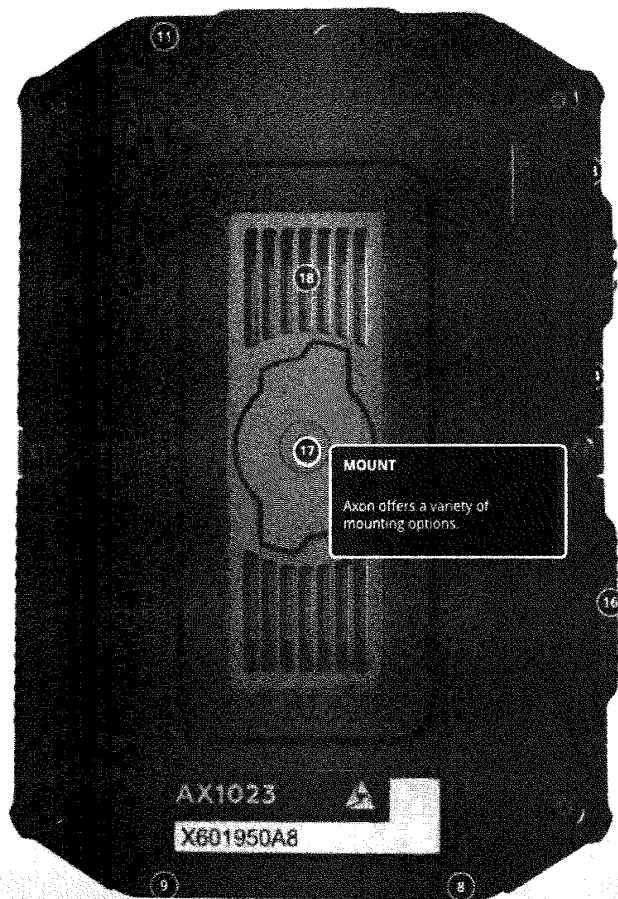

MOUNT
Axon offers a variety of mounting options.

AX1023
X601950A8



AB3 | MOUNT

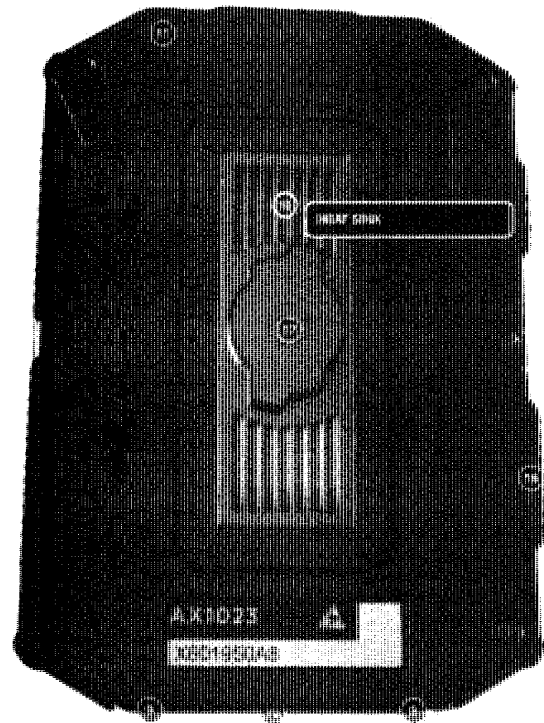

AB3 | HEAT SINK

OPERATING FUNCTIONS

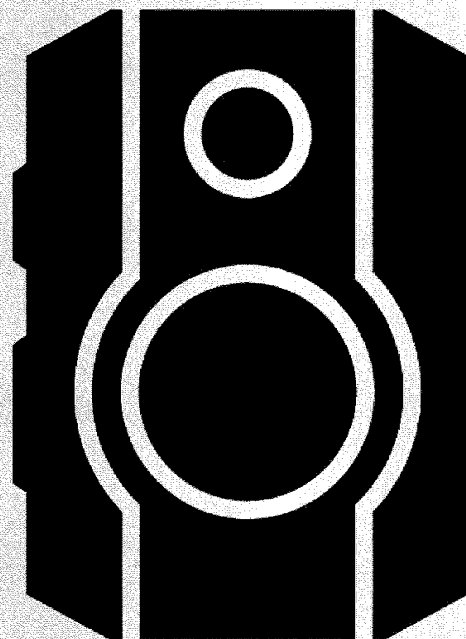

BUFFERING MODE



The Buffering Mode is 1 Minute, no audio .

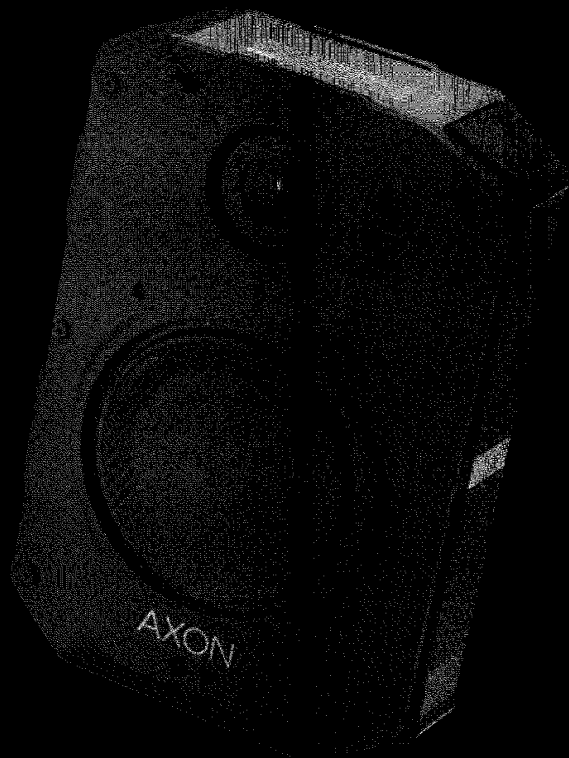

BUFFERING MODE



RECORDING VIDEO



To start a recording, double
press the Event Button

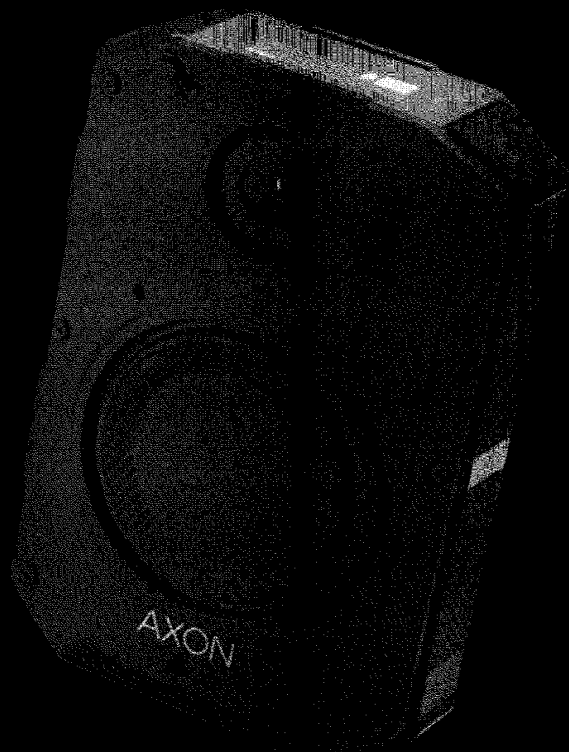

*While recording, the AB3 will beep and vibrate every two minutes to remind user it is recording.

RECORDING VIDEO



To end a recording, hold the Event Button for approximately 3 seconds

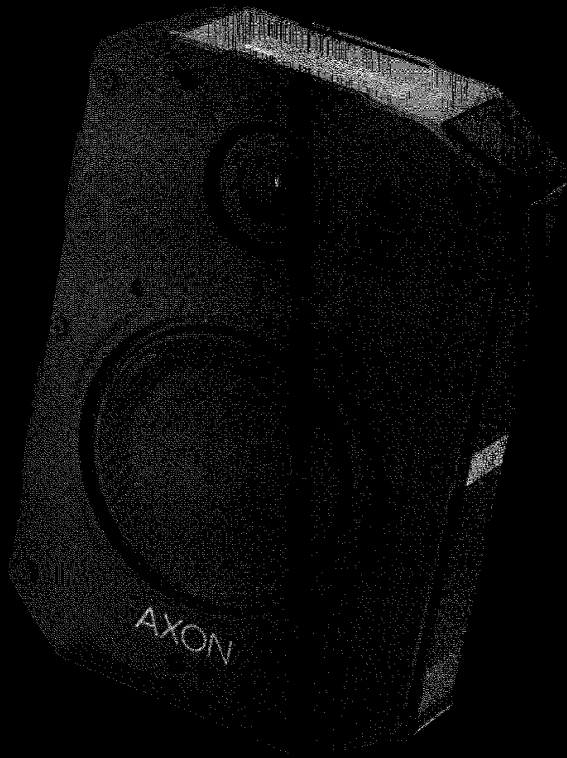

MUTING AUDIO



While in Record mode hold the Select Button for 3 seconds to activate Mute Mode

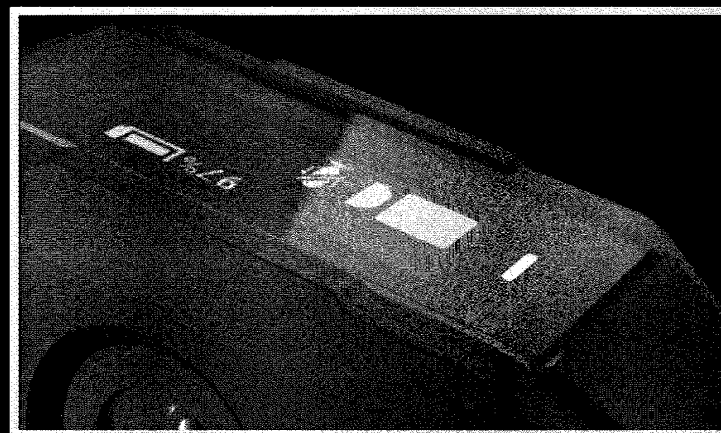
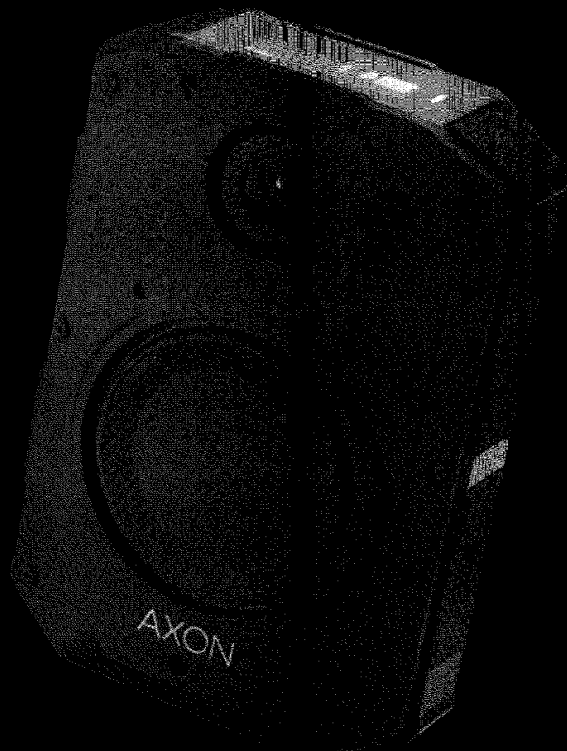

To confirm, the AB3 will beep, vibrate, display the mute icon, and the operation LED will blink blue (if enabled)



MUTING AUDIO

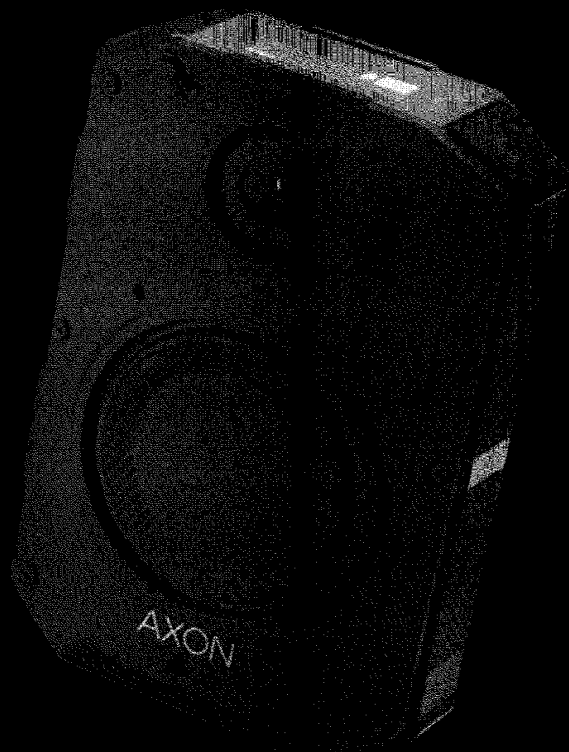

To deactivate Mute Mode hold the Select Button for 3 seconds



To confirm deactivation, the AB3 will beep, vibrate, the mute icon will disappear, and the operation LED will blink red (if enabled)



■ ADDING MARKERS

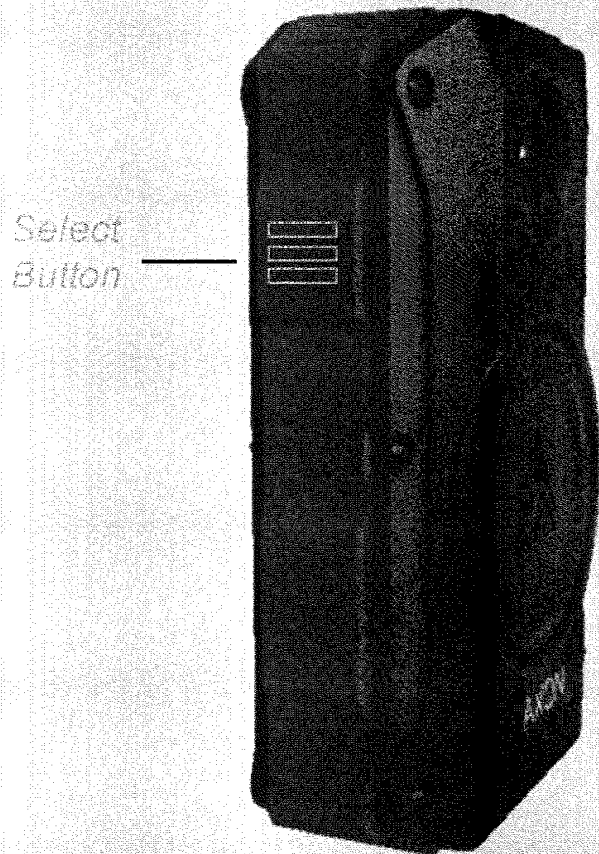

To add a marker: Press and release the Select Button. The AB3 will vibrate to confirm a Marker was added

■ SPEAKER VOLUME

Volume
Up —



Volume
Down —

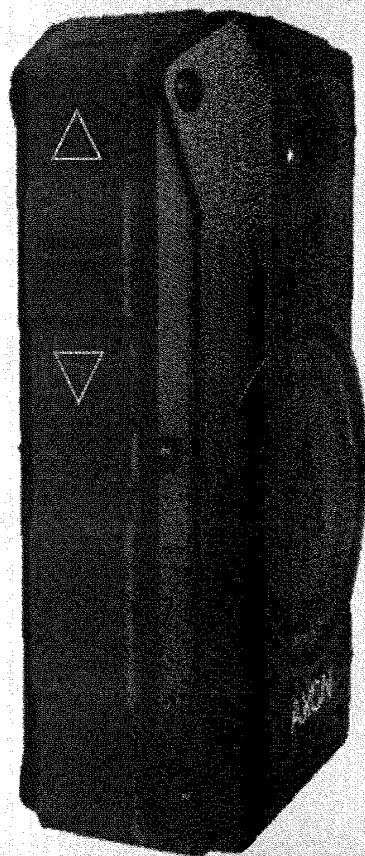

Increase Speaker Volume:
Press Volume Up Button

Decrease Speaker Volume:
Press Volume Down Button

■ STEALTH MODE

Volume
Up

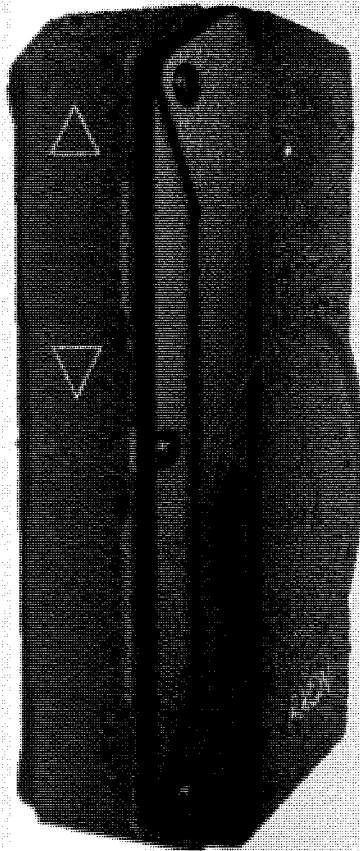

Volume
Down

*Turns off the Operation LED, Triad LED, audio prompts, and haptic feedback

Enter Stealth Mode: Press and hold Volume Down button for 3 seconds

Exit Stealth Mode: Press and hold Volume Up or Down button for 3 seconds

■ OTHER OPERATING MODES

Volume
Up ———
Select
Button ———

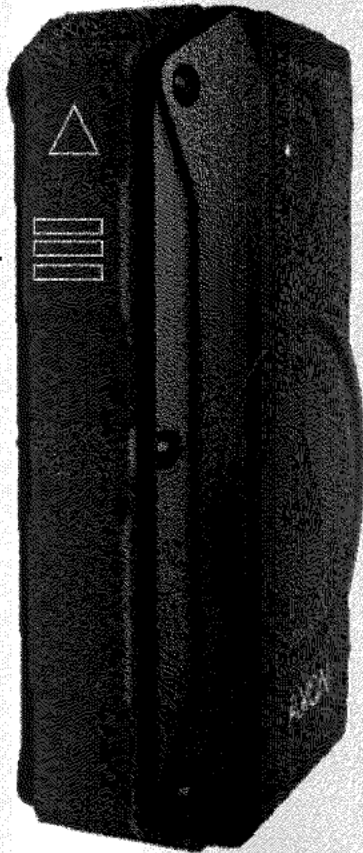

Activate Lights On or Off: Press and hold Volume Up button for 3 seconds

Activate Display Backlight: Double Press Select Button (Backlight activates for 5 seconds)

PRIORITY EVIDENCE UPLOAD

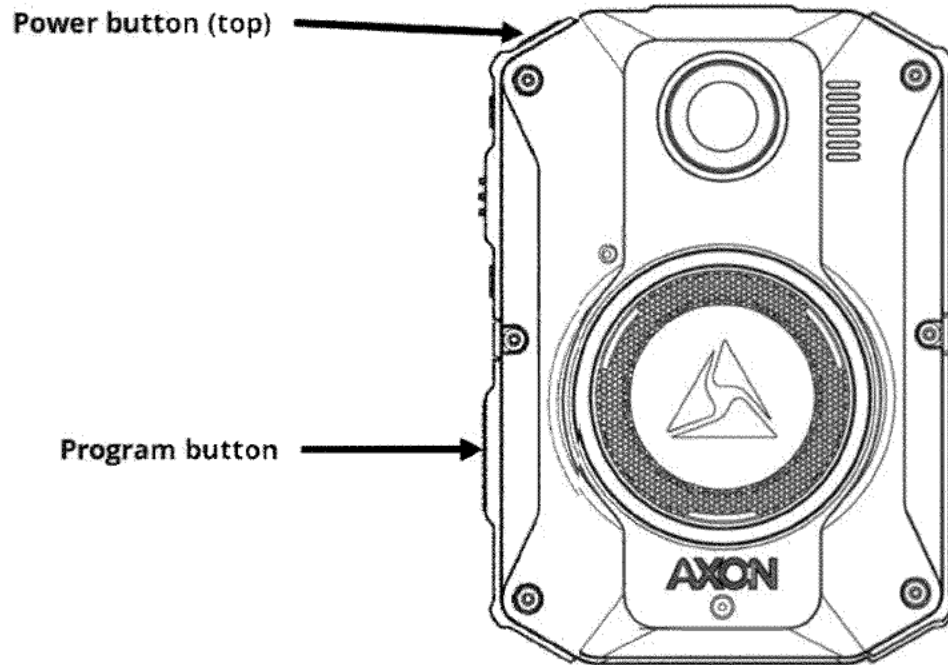

Initiate a Priority Evidence Upload: Press the Power AND Program Button at the same time

PRIORITY EVIDENCE UPLOAD

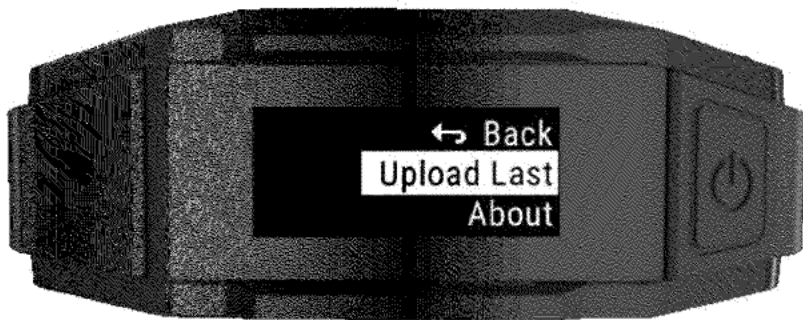

Use the Volume Up or Volume Down button to highlight **Upload Last** then press the Select button

PRIORITY EVIDENCE UPLOAD

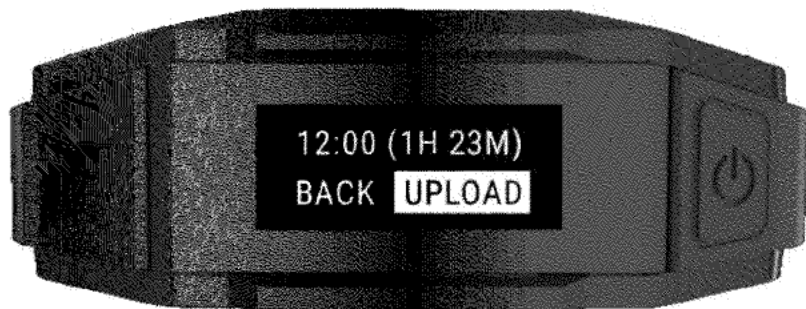

Use the Volume Up or Volume Down button to highlight **Upload** then press the Select button

PRIORITY EVIDENCE UPLOAD

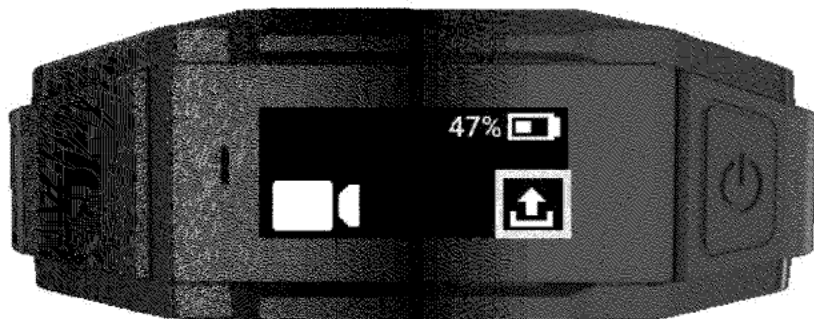
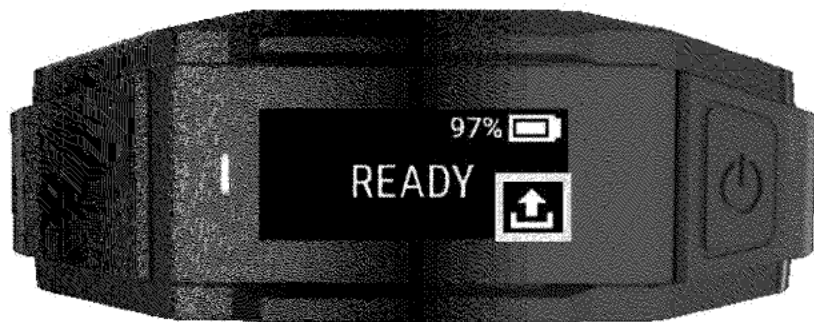

Once an upload has begun, the **Upload** icon is displayed while **READY** or **RECORDING**

PRIORITY EVIDENCE UPLOAD



Once the evidence has uploaded successfully, **UPLOAD COMPLETE** will be displayed, and the evidence deleted from the camera

CANCELING AN UPLOAD

Power button (top)

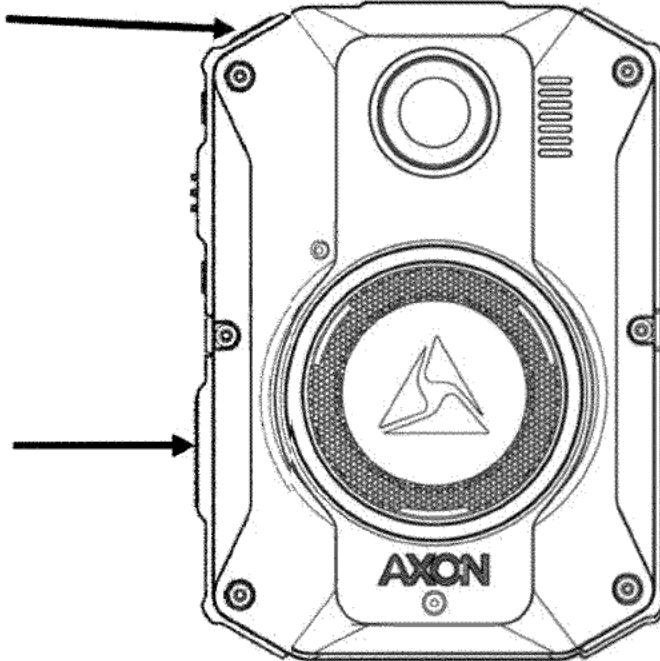

Program button

Press the Power AND Program
Button at the same time

CANCELING AN UPLOAD

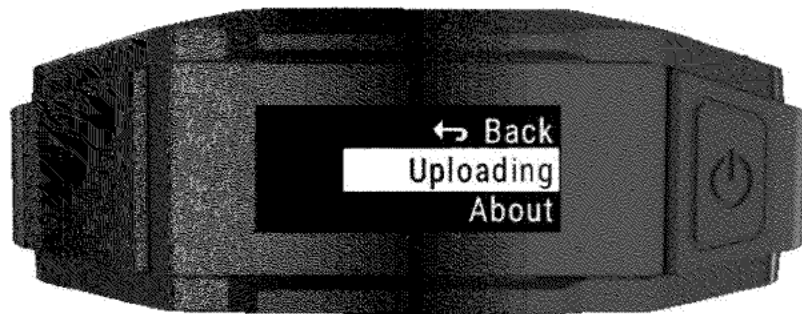

Use the Volume Up or Volume Down button to highlight **Uploading** then press the Select button

CANCELING AN UPLOAD



Use the Volume Up or Volume Down button to highlight **Cancel** then press the Select button

CANCELING AN UPLOAD



An **Upload Canceled** confirmation message is displayed for 3 seconds and the evidence upload is canceled

■ BUTTON ACTION RECAP

Action	Button Actions
Power On	Press Power button until short vibration. Camera starts and enters Ready (Buffering) mode.
Power Off	Press and hold Power button for 3 seconds.
Start recording	Double-press Event button.
End recording	Press and hold Event button for 3 seconds.
Add marker to recording	While recording, press Select button.
Increase speaker volume	Press Volume ▲ button.
Decrease speaker volume	Press Volume ▼ button.
Turn lights on or off	Press and hold Volume ▲ button for 3 seconds.
Enter Stealth mode	Press and hold Volume ▼ button for 3 seconds.
Exit Stealth mode	Press and hold Volume ▲ or Volume ▼ button for 3 seconds*.
Enter or exit Mute mode	While recording, press and hold Select button for 3 seconds.
Activate display backlight	Double-press Select button. Display backlight turns on for 5 seconds.

* - The camera remembers volume and light settings when exiting Stealth mode.



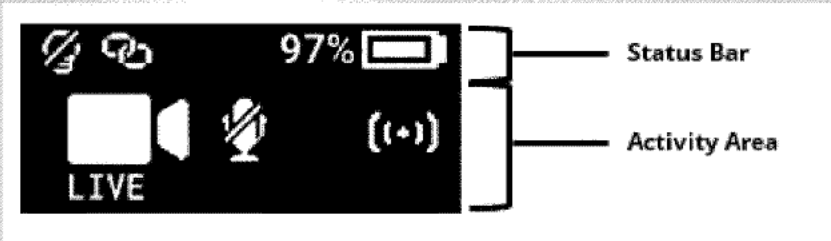





AB3 DISPLAY



Status Bar Icon	Description
	Battery capacity
	Lights off
	Stealth mode on
	Battery low warning (to the right of the battery capacity icon)

Activity Area Icon	Description
	Ready (Buffering) mode
	Recording
	Axon Respond Livestreaming*
	Microphone off (mute mode)

AB3 DISPLAY & NOTIFICATIONS

Operating Mode or Action	Camera Display (Activity Area)	Operation LED	Audio Notification	Haptic Notification (Vibration)
Power on	 then READY	Solid red	Two short rising-pitch tones	One - long duration
Power off		Solid red	Three short lowering-pitch tones	One - long duration
Recording started by Event button double-press	STARTING then 	Blinking red	Two short tones	Two - short duration
Recording reminder		Blinking red	Two short tones every 2 minutes	Two - short duration every 2 minutes
Stop recording, return to Ready	SAVING then READY	Blinking green	One long tone	One - long duration
Volume up or down		Blinking green or red	One short tone at new volume level	One - short duration
Axon Respond Livestreaming	 LIVE	Blinking purple	Three short rising-pitch tones	One - long duration
Enter or Exit Mute mode (microphone off)	 	Blinking blue in Mute mode	One short tone	Two - long duration
Enter Stealth mode	STEALTH	Off	None	None
Exit Stealth mode	No change	Blinking green or red	None	Two - short duration
Event marker captured		Blinking red	None	One - short duration
Low battery notifications: 20% battery capacity and every 5% decrease OR any error	BATTERY LOW	Blinking yellow	Four quick high-pitch tones	Four - short duration

AXON RESPOND & RESPOND +

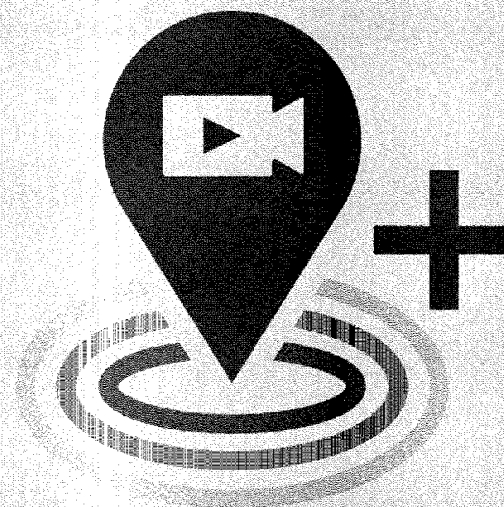

WHAT IS RESPOND & RESPOND +



Respond is Axon's new real-time situational awareness technology

The AB3 is connected to LTE - similar to a cell phone - and can livestream to Axon Evidence instantaneously to authorized users when the AB3 is recording. GPS is also activated if camera is on and recording, or during pre-event buffer, if enabled

RESPOND & RESPOND +



	Respond	Respond +
Real-time alerts (gunshot)	X	X
Managed LTE Connectivity	X	X
Gunshot Detection	X	X
Live Maps	X	X
Live Streaming		X

RESPOND WORKFLOW



1. In the field, an AB3 operator begins a recording
2. At the station, an authorized user opens Axon Evidence and clicks on the Respond tab to see the live map
3. The AB3 operator's GPS marker updates from grey to green on the live map when they begin recording
4. The authorized user clicks on that AB3 operator's marker (or name) and their camera details populate the right side of the screen
5. The authorized user clicks "Start livestream." The AB3 operator is notified through an icon display, haptic feedback, and an Operation LED color change (if enabled)
6. The authorized user ends the livestream by clicking "End livestream" or leaving the webpage, OR the AB3 operator ends the livestream by ending their recording

LIVESTREAMING



When a livestream is started, the AB3 operator is notified through an icon display, audio prompt, haptic feedback, and Operation LED color change (if enabled)

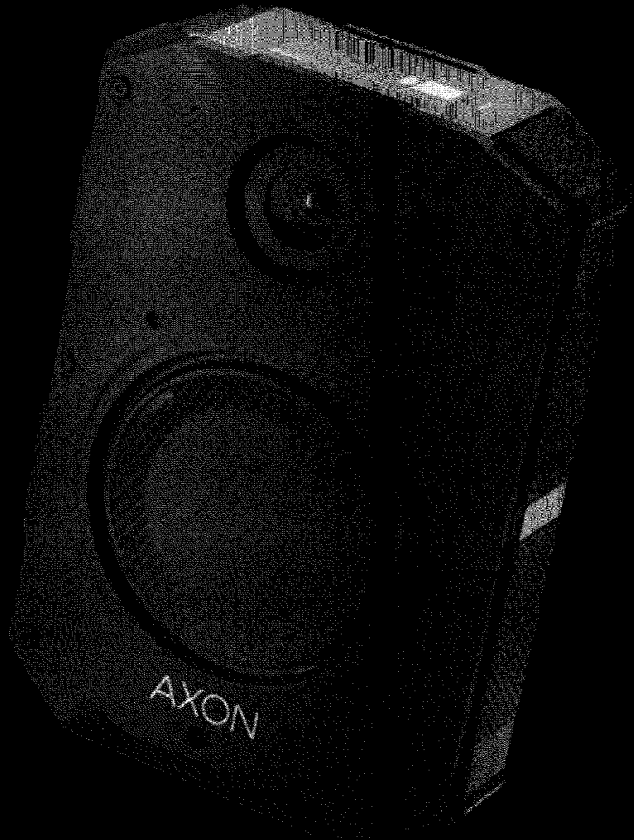





*Livestreaming is only available while the AB3 is in Record Mode

LIVE MAP BUBBLES



Camera Markers

	Camera recording, available for livestream. Light blue color indicates location was last updated more than 5 minutes ago.
	Camera not recording. This is last location update when camera stopped recording. This marker is removed after 4 hours.
	Multiple cameras, indicated by number, at location. Click or manually zoom in to see individual camera markers.
	Approximate camera location as reported by GPS. The camera is in the circle, but not necessarily in the center. Shown when Recording List location is clicked.
	Alert associated with camera. Alert status is removed after 8 hours.

AXON FLEX 2 OVERVIEW

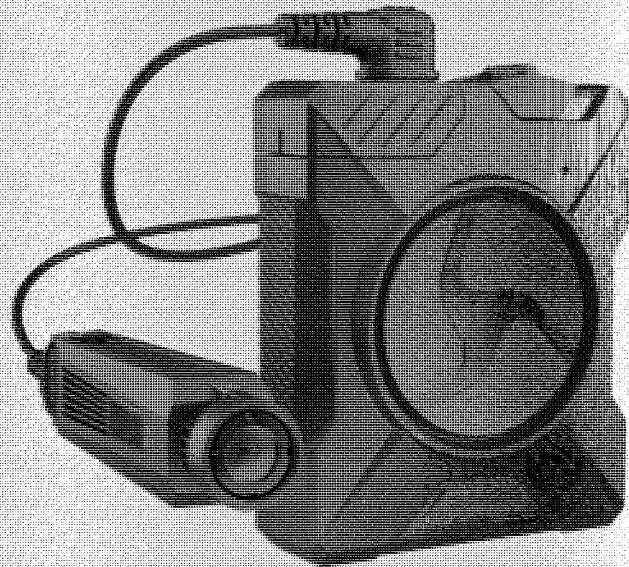

AXON FLEX 2 OVERVIEW

- 12+ hours of battery life under normal operation
- Up to 30 frames per second
- 120° diagonal field of view camera lens
- IP54 rated
- 640 x 480 VGA, 1280 x 720 HD, 1920 x 1080 HD
- Up to 70 hours of record time
- Multicam playback



■ CAMERA CARE

Cleaning the camera

- Use a soft, damp cloth to clean the surface.
- Do not use harsh cleaners or solvents.
- Do not immerse the Axon body camera in water or cleaning solutions.
- If the Axon body camera lens becomes dirty, use a lens wipe or moisten the cloth.
- Do not use Windex® or similar type cleaners on the camera lens.

Cameras are water resistant...but not waterproof

- Do not place the lens under running water or apply jets of water to the camera lens.

AXON FLEX 2 CONTROLLER OPERATING FUNCTIONS

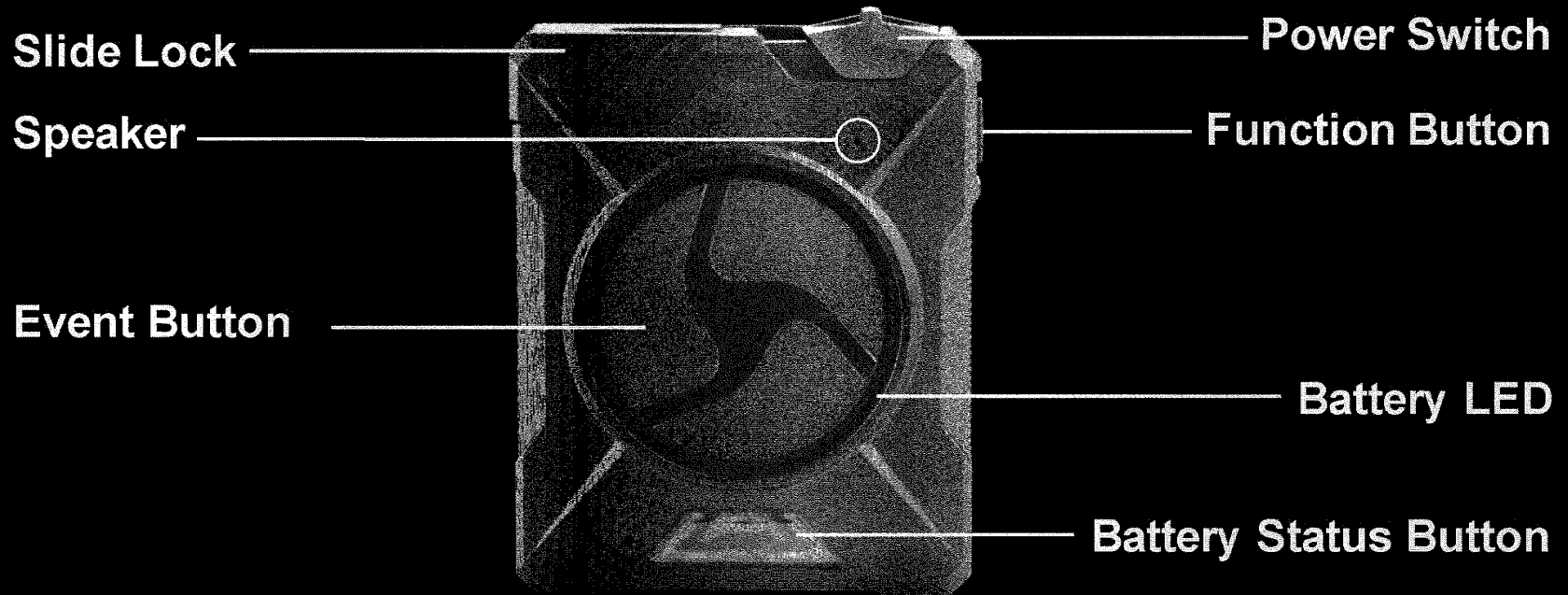

FRONT VIEW

AXON FLEX 2 CONTROLLER OPERATING FUNCTIONS

Cable
Connection
Port

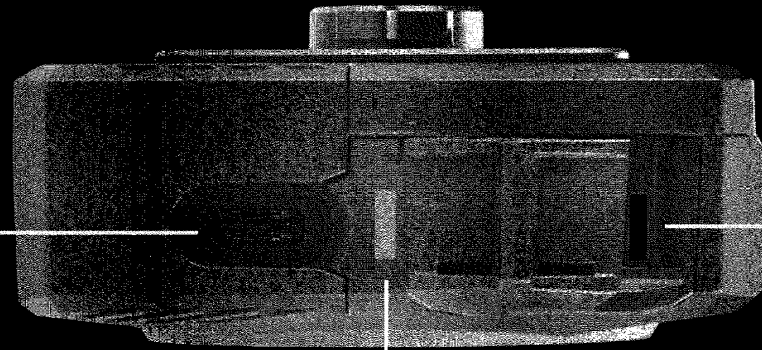

Operation LED

Function LED

TOP VIEW

AXON FLEX 2 CONTROLLER OPERATING FUNCTIONS

Dock
Status
LED



Controller
Serial
Number

BOTTOMVIEW

AXON FLEX 2 CAMERA

Camera
Serial
Number

X83001234

Mount
Attachment

Imager
(Lens)



BOTTOMVIEW

AXON FLEX 2 CAMERA

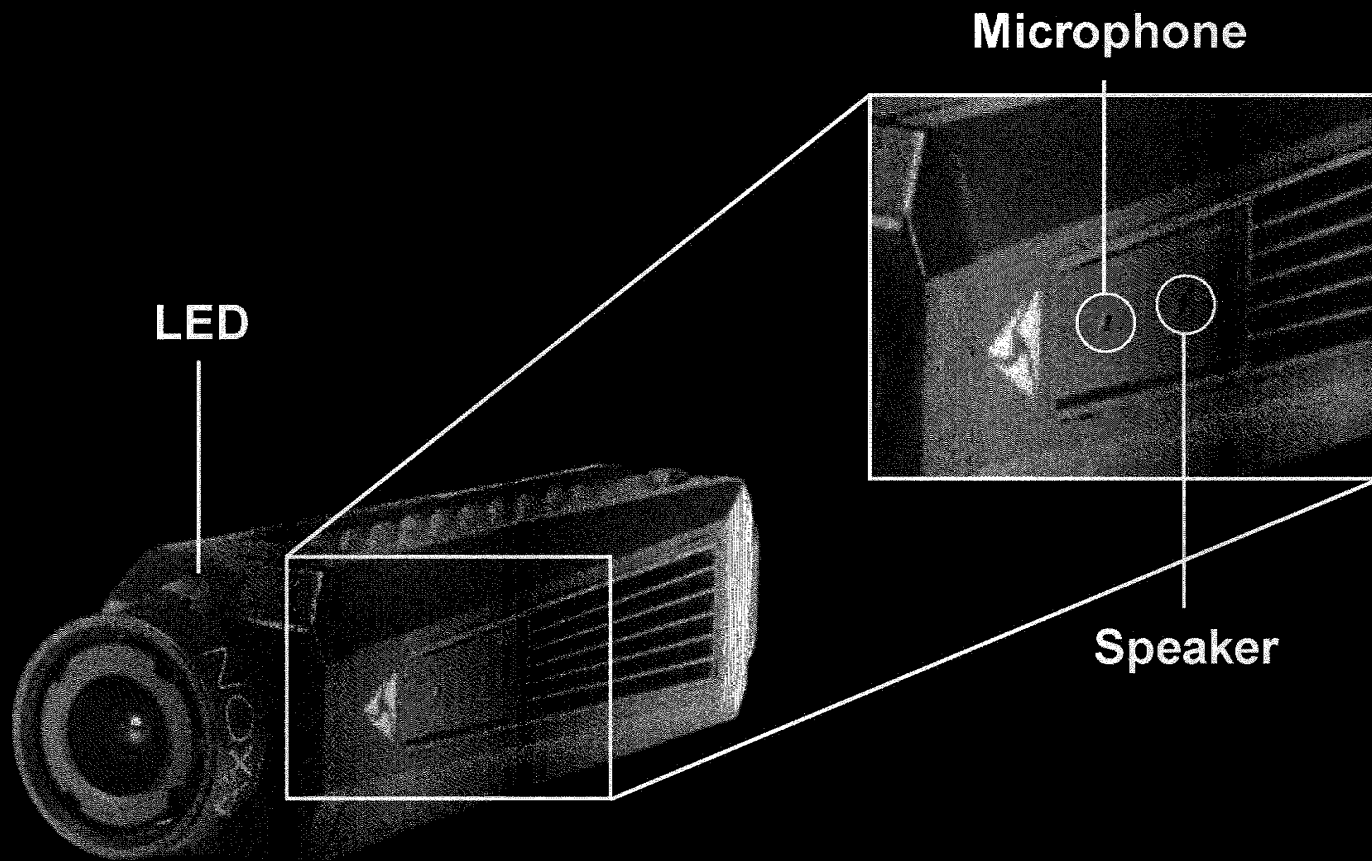

TOP VIEW

AXON FLEX 2 CAMERA

Cable
Connection
Port

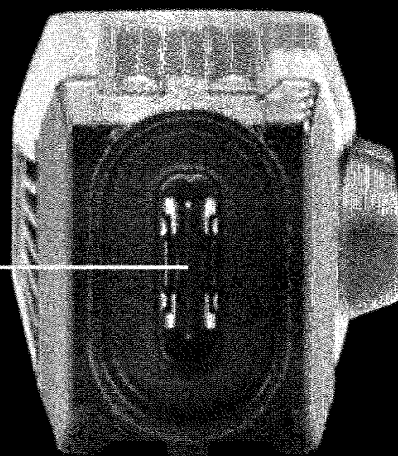

BACKVIEW

AXON FLEX 2 CONNECTING COMPONENTS

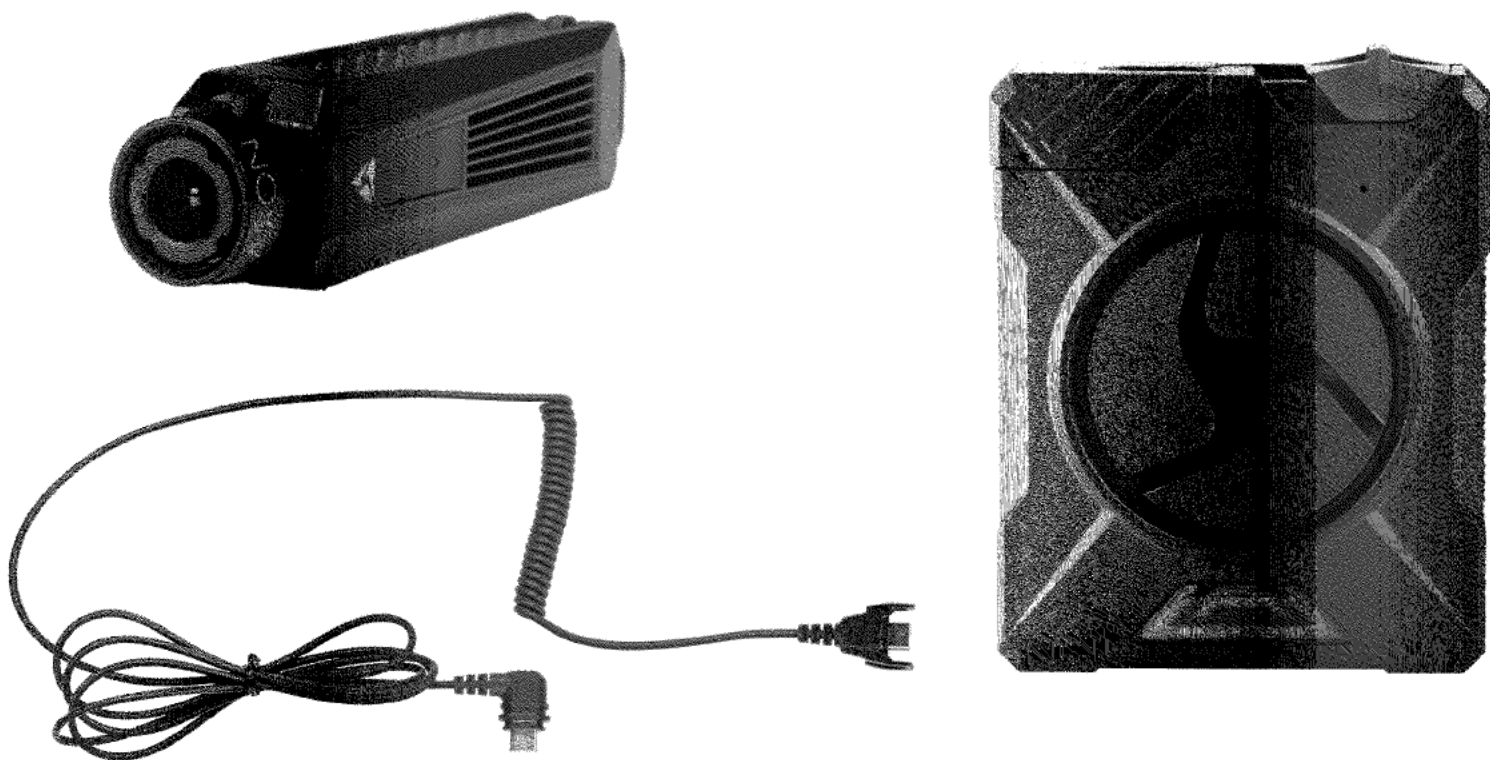

AXON FLEX 2 CONNECTING COMPONENTS

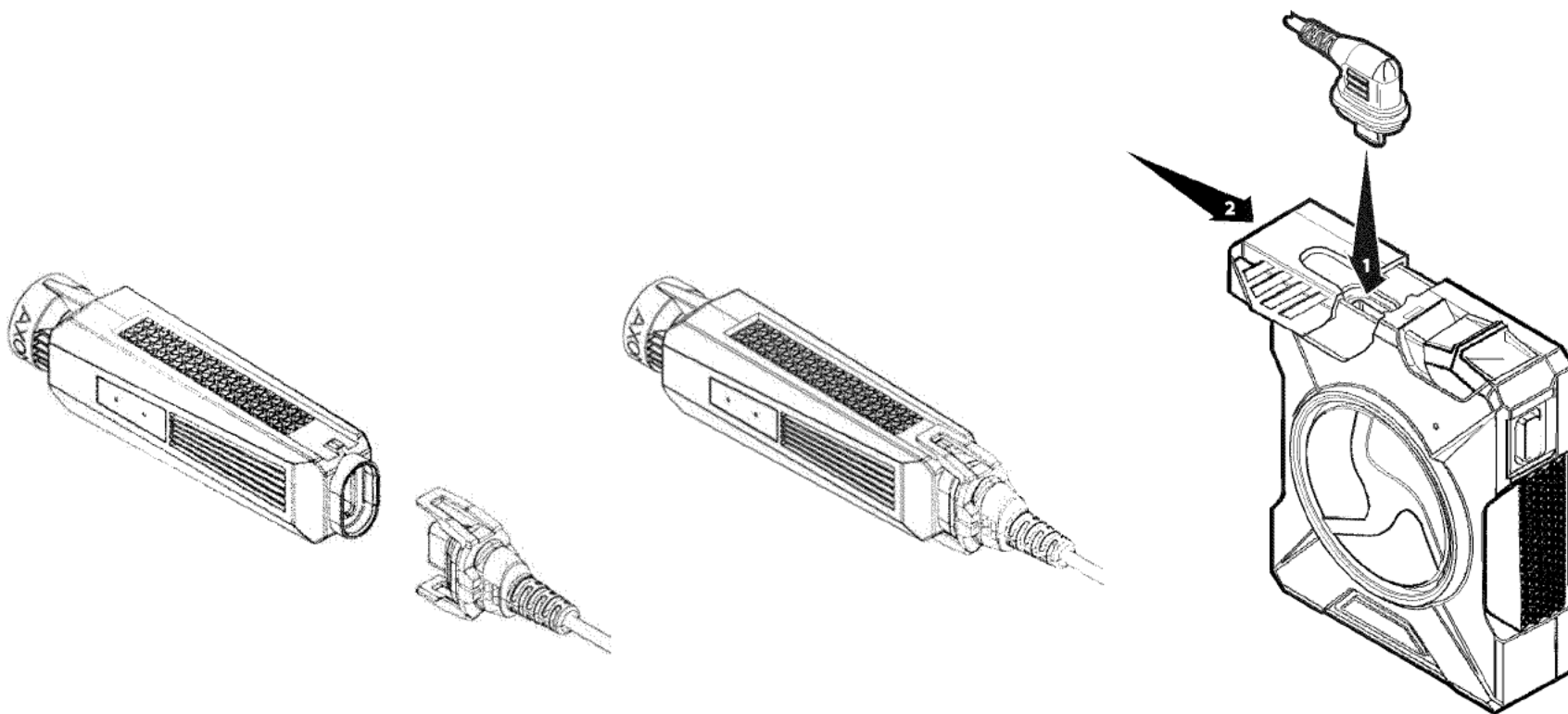

AXON FLEX 2 CONNECTING COMPONENTS

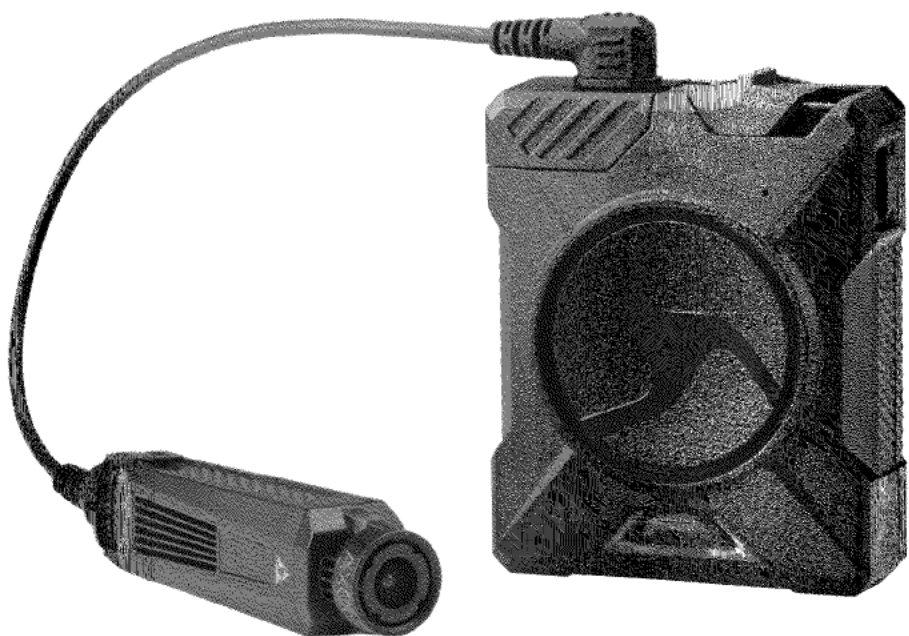

BUFFERING MODE



The **BUFFERING** mode is
1 Minute prior to a recording, no audio.

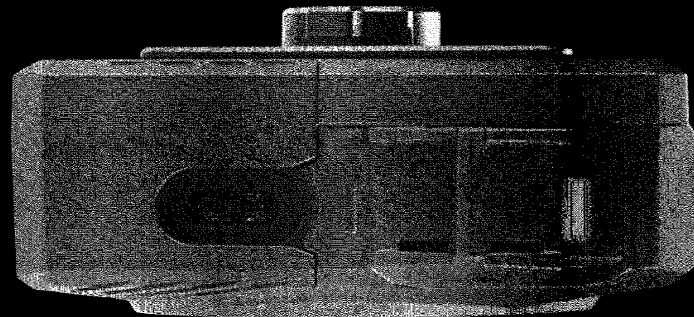

RECORDING VIDEOS

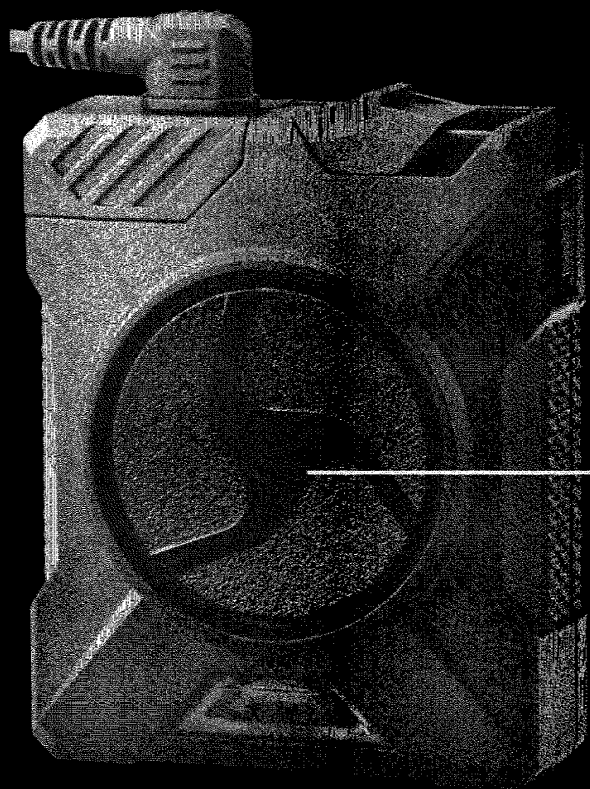

To start recording video,
double press the **Event Button**.

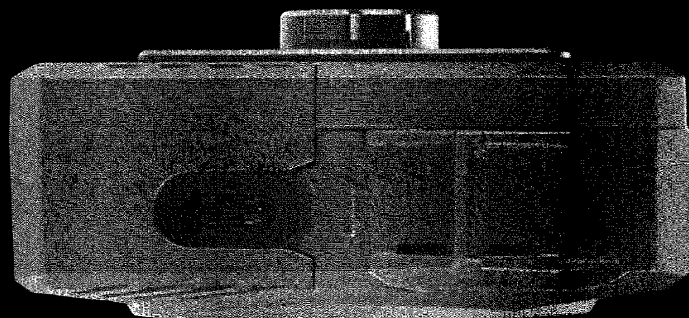

* In record mode the camera will beep and vibrate every two minutes

RECORDING VIDEOS

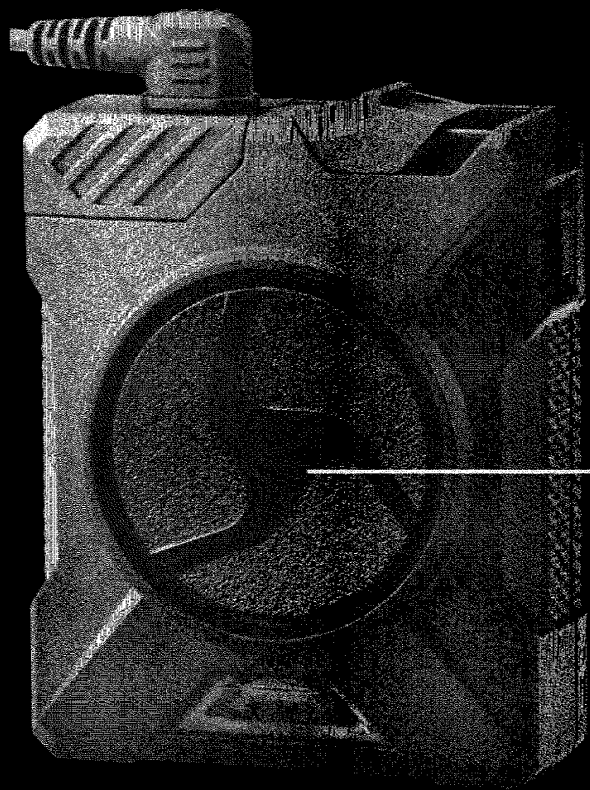

To stop recording, press and hold the **Event Button**.

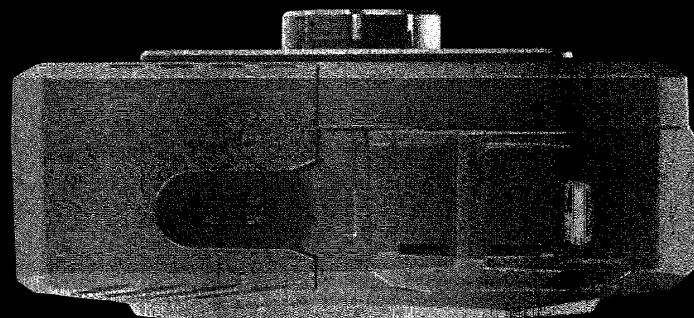

OPERATING MODES

Operation LED	Operating Mode
Solid Red	Booting Up
Blinking Green	Buffering
Blinking Red	Recording
Blinking Yellow	Cable Disconnect

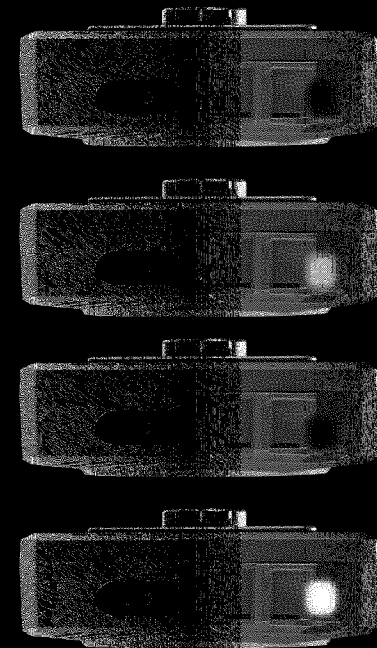

MOUNTS

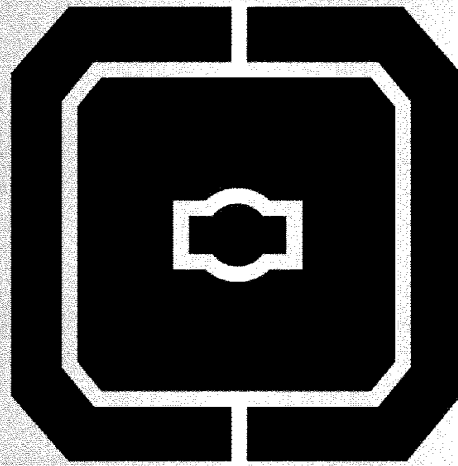

MOUNTS

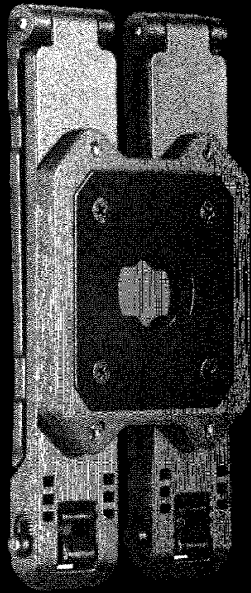

Double MOLLE

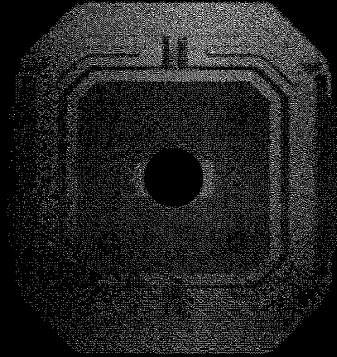

Wing Clip

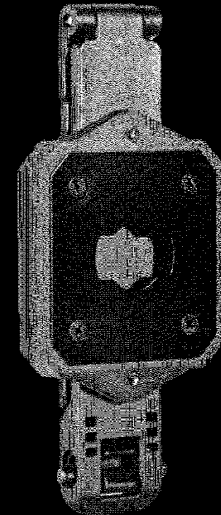

Single MOLLE

AF2 CAMERA MOUNTING

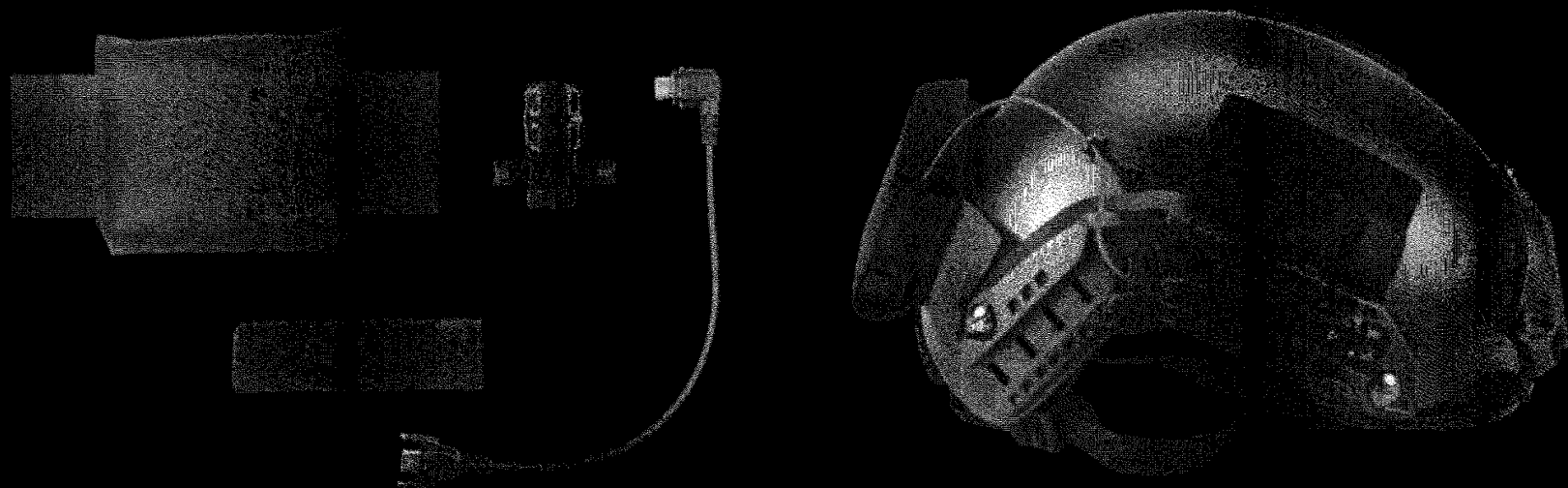

SWAT Helmet Mount

DOCKING

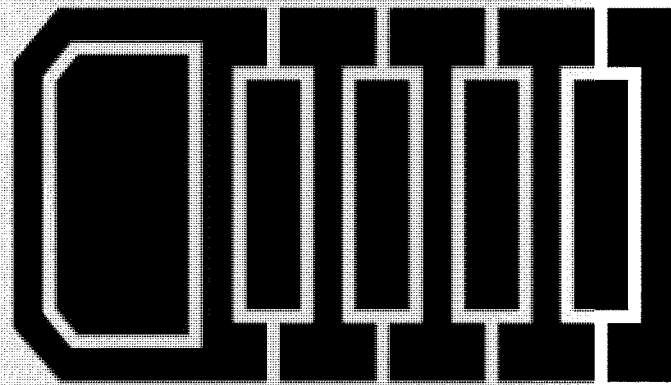

AB3 DOCKING AND CHARGING

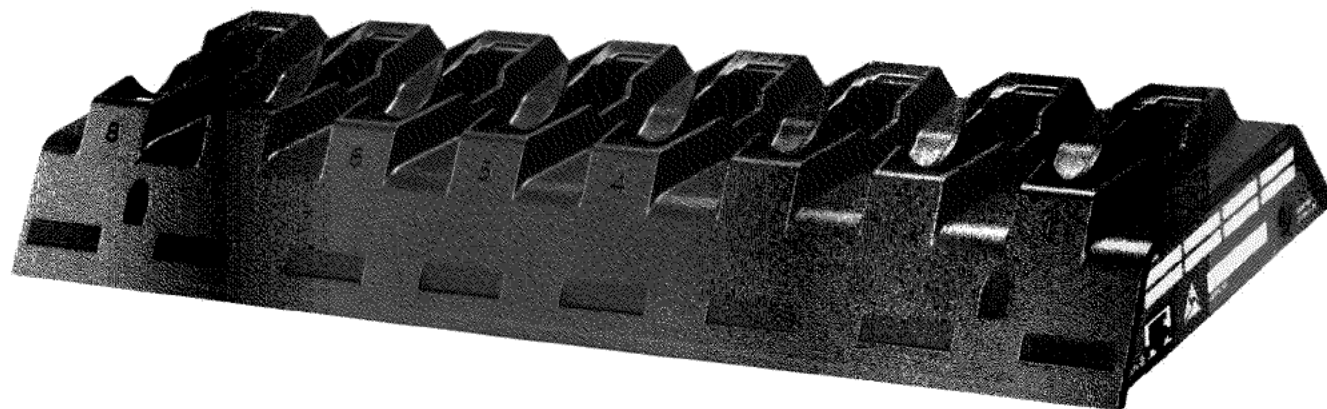

TRIAD LED IN DOCK

Indicators during the upload process



Uploading Data
CYCLING YELLOW



Upload Complete & <33% charge
SOLID RED



Upload Complete & 33% - 97% charge
SOLID YELLOW

TRIAD LED IN DOCK

Indicators during the upload process



Upload Complete & >98% charge
SOLID GREEN



Firmware Update
CYCLING WHITE





Network Error
CYCLING RED, YELLOW, GREEN

AB3 DISPLAY & TRIAD LED IN DOCK



Indicators during the upload process

Device Status	Camera Display		Triad LED
	Activity Area	Status Bar	
Uploading data	UPLOADING 1/10		Spinning yellow (cycling on each Triad LED)
Downloading data or applying device settings	UPDATING		Spinning yellow (cycling on each Triad LED)
Applying firmware update	UPDATING		Spinning white (cycling on each Triad LED)
Possible network error. Check network connection and refer to Troubleshooting section of the Axon Body 3 User Manual or go to help.axon.com .	NETWORK ERROR		Blinking red and green
Device error. Refer to device page in Axon Evidence.	DEVICE ERROR		Blinking red
Assigned user ID - shown when no other activity, other than charging, and for 10 seconds after removing from dock	USERID123		Battery capacity
Battery capacity. The charge indicator  is shown to the right of battery capacity during charge	Any of the above	50% 	Solid green (≥ 98%)
			Solid yellow (33% to 97%)
			Solid red (< 33%)

■ AF2 DOCKING & CHARGING THE CAMERA

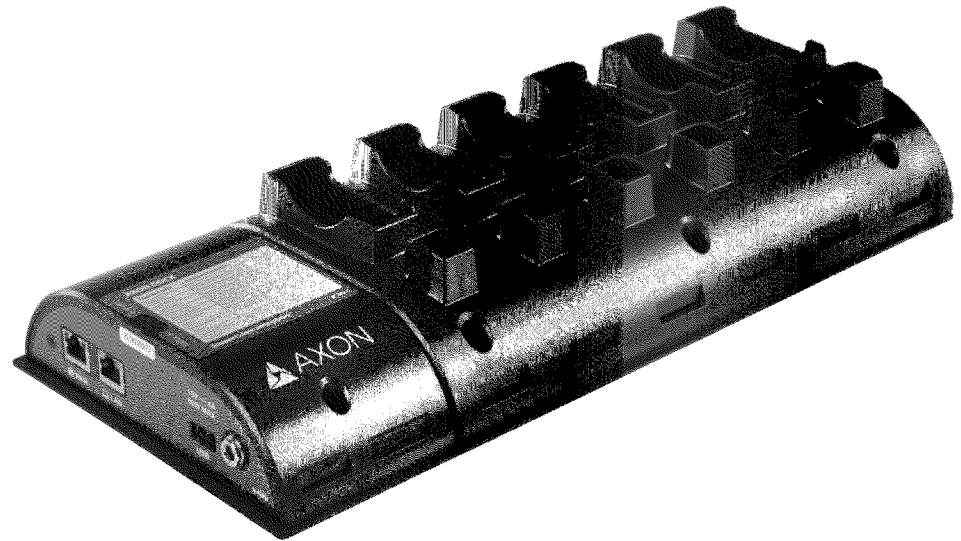

CAMERA LED INFORMATION

Indicators during the upload process

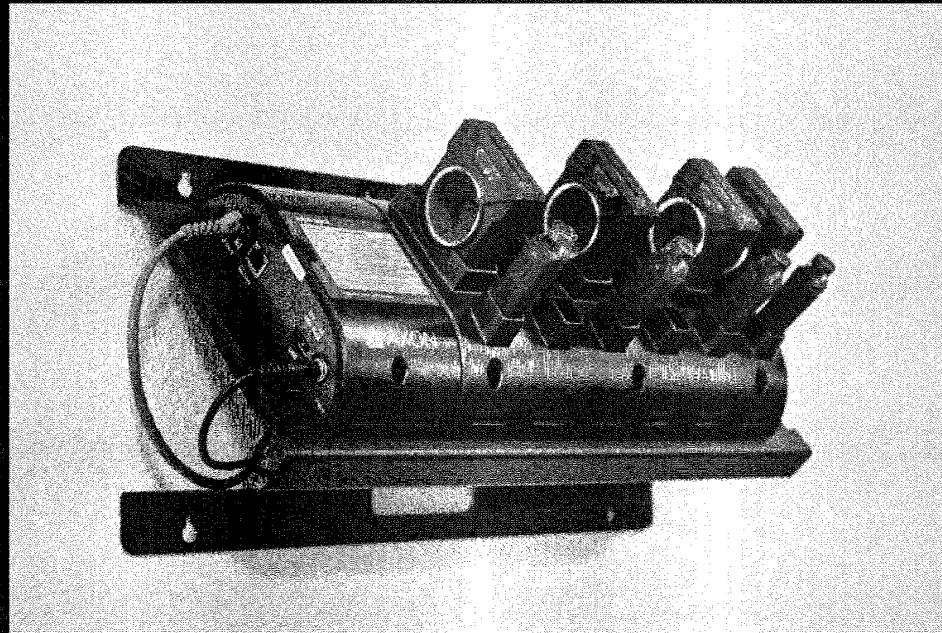

Initial connection (momentary)

LED ON for 20 seconds or fewer

CAMERA LED INFORMATION

Indicators during the upload process

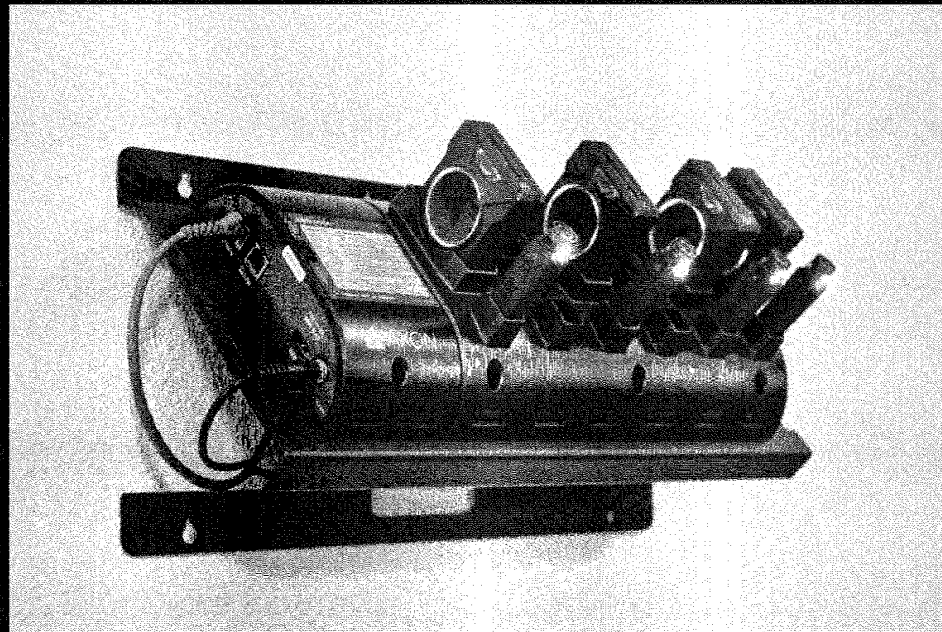

In queue awaiting upload
SOLID YELLOW

CAMERA LED INFORMATION

Indicators during the upload process

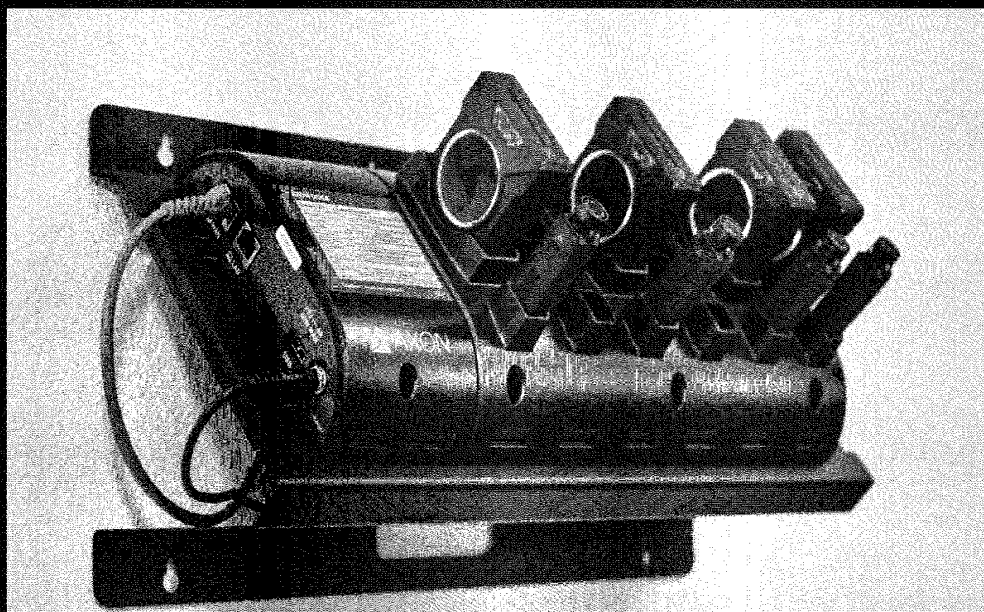

Uploading data
BLINKING YELLOW

CAMERA LED INFORMATION

Indicators during the upload process

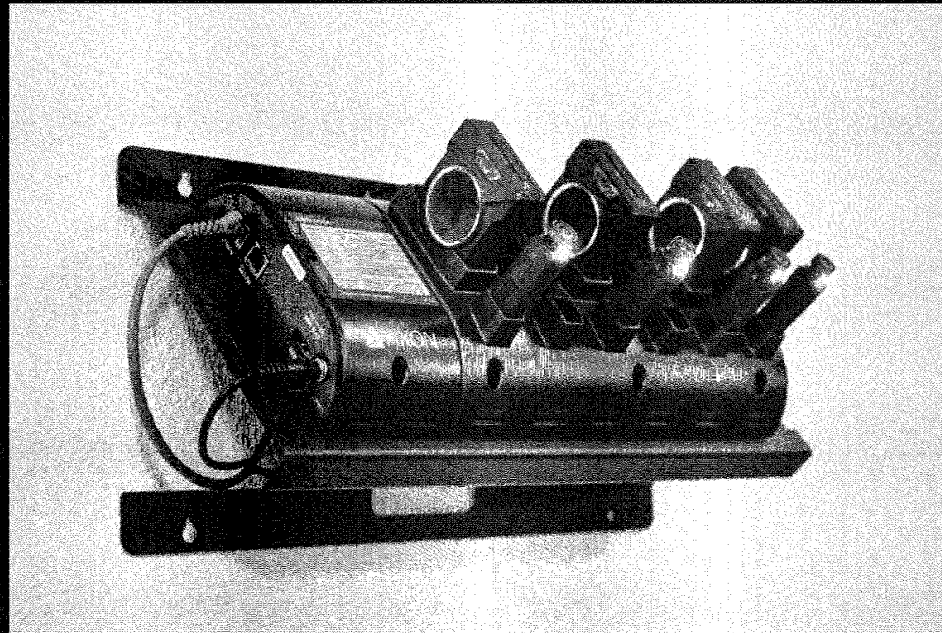

File upload complete
SOLID GREEN

CAMERA LED INFORMATION

Indicators during the upload process

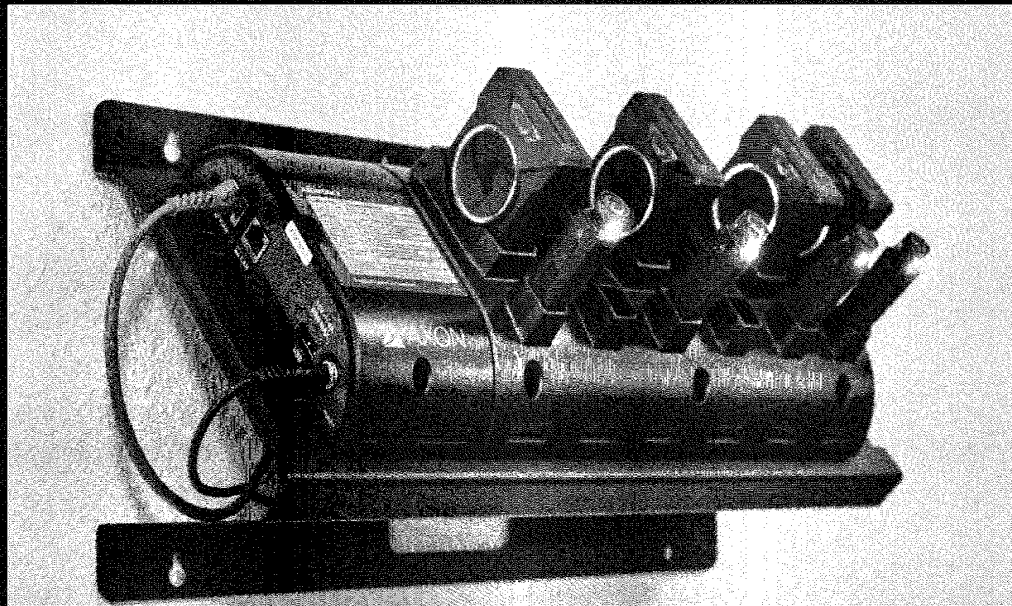

Firmware update - DO NOT REMOVE
POWER & BATTERY RED & YELLOW

CAMERA LED INFORMATION

Indicators during the upload process

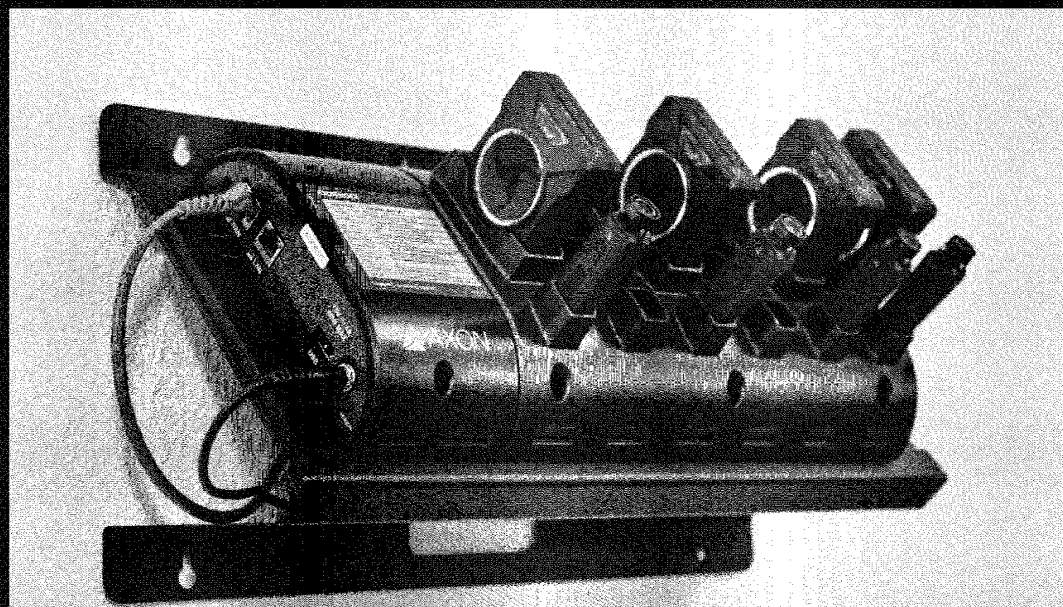

Agency device mismatch

BLINKING RED

CAMERA LED INFORMATION

Indicators during the upload process

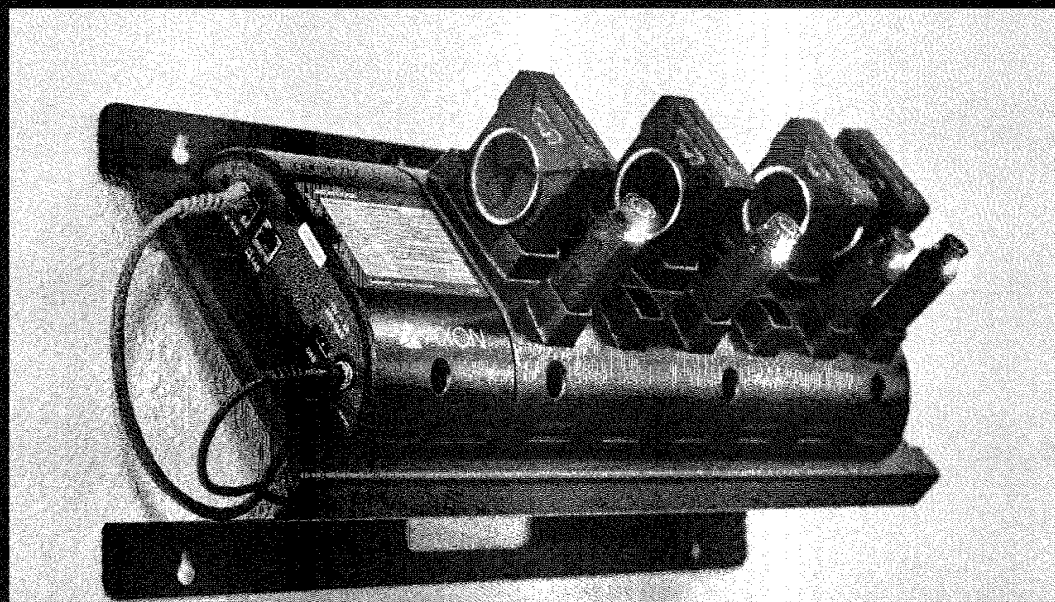

Transfer error, device re-trying to transfer
BLINKING GREEN & YELLOW

CAMERA LED INFORMATION

Indicators during the upload process

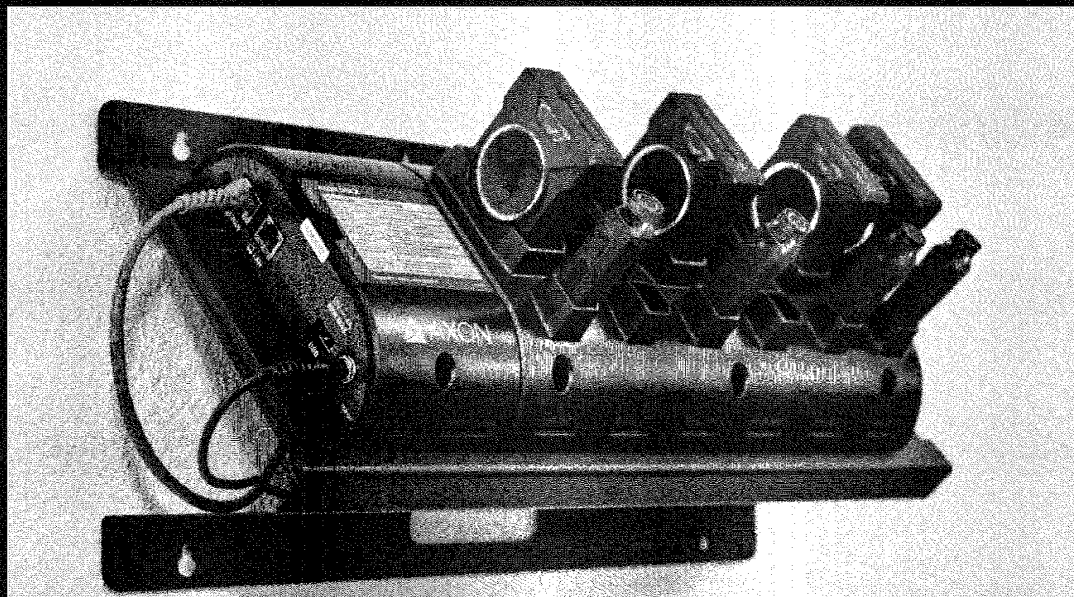

Network error - no connection

BLINK

YELLOW, & THEN GREEN (cycling all colors)

CAMERA LED INFORMATION

Indicators during the upload process

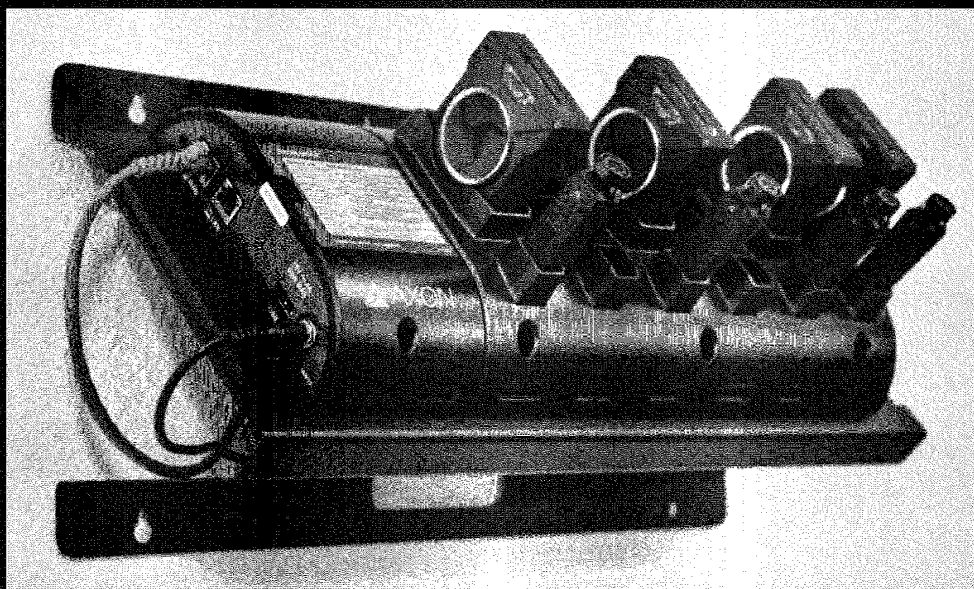

Axon Dock has no communication with the camera
LED OFF

AXON CAPTURE

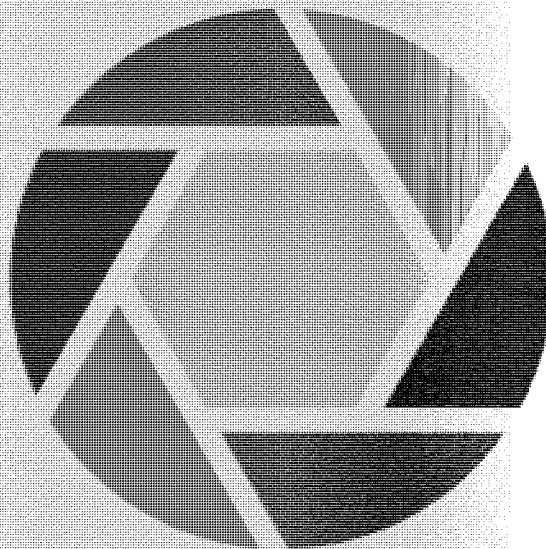

AXON CAPTURE

- Captures digital evidence directly from the field
- Eliminates the need to use alternative devices for photo, video, and audio recording
- Ability to add metadata and GPS coordinates to any evidence uploaded
- Ability to utilize Axon Citizen

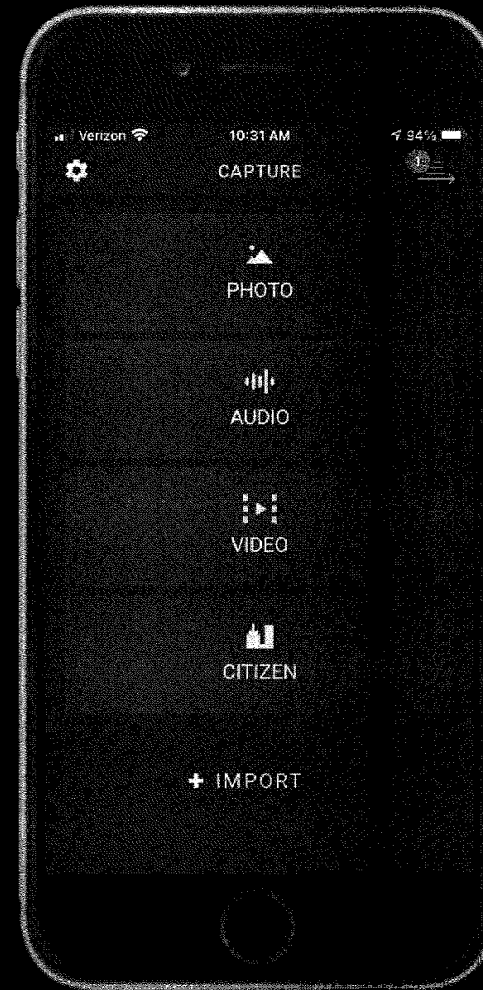

AXON CAPTURE



Step 1

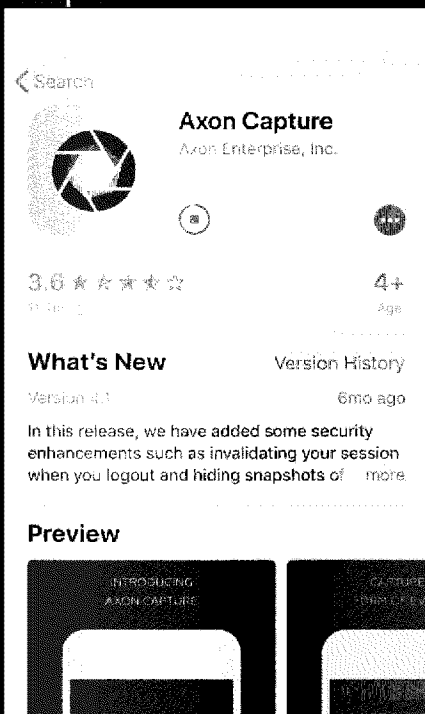

DOWNLOAD THE APP

Step 2

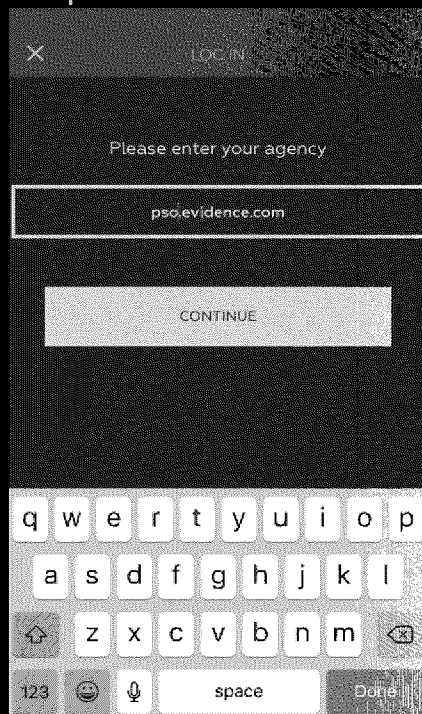

ENTER YOUR AGENCY

Step 3

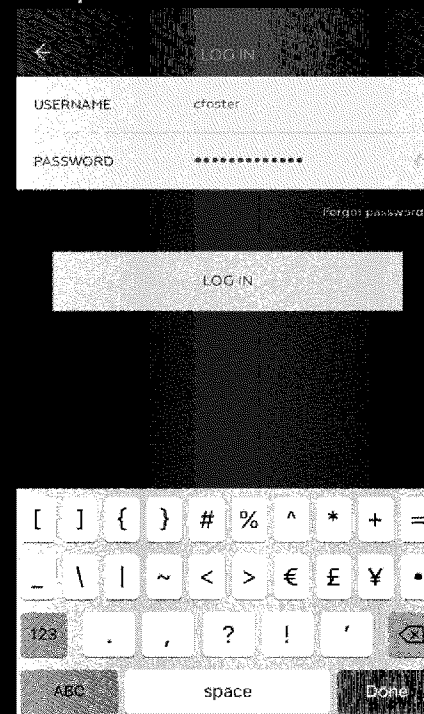

LOG IN USING AXON EVIDENCE CREDENTIALS

AXON CAPTURE



Step 4

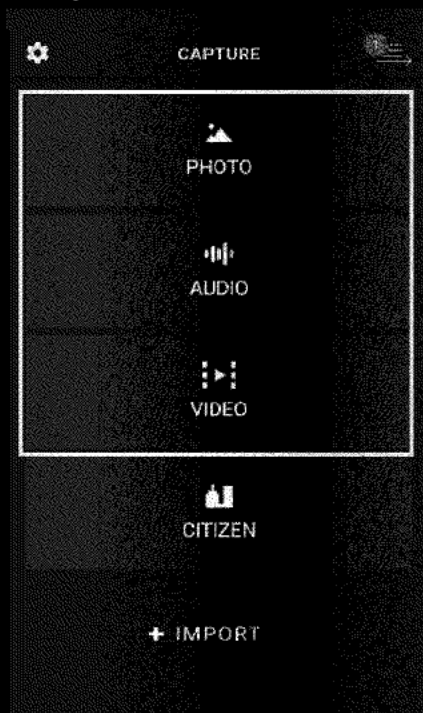

TAP ON CAPTURE METHOD

Step 5



CAPTURE EVIDENCE

Step 6



ADD METADATA & REVIEW

AXON CAPTURE

EVIDENCE WILL UPLOAD
DIRECTLY INTO YOUR AXON
EVIDENCE ACCOUNT

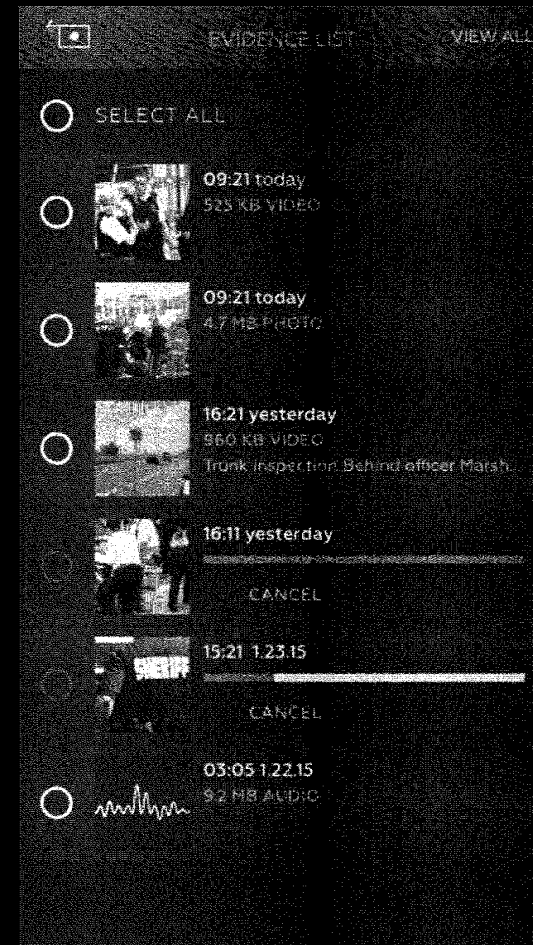

AXON CAPTURE - BULK EDIT



Step 4a

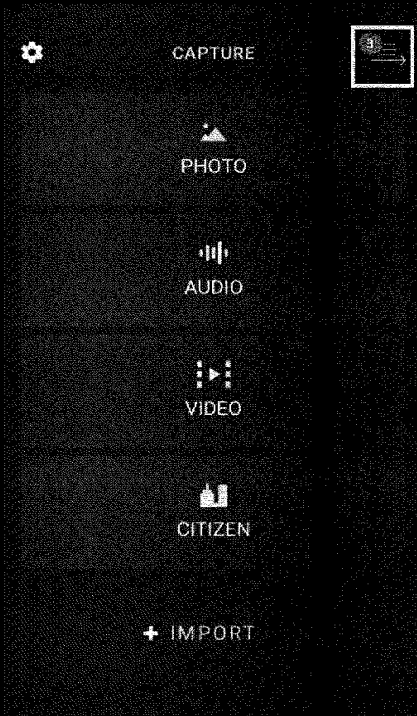

TAP ON EVIDENCE LIST

Step 5a



SELECT EVIDENCE

Step 6a

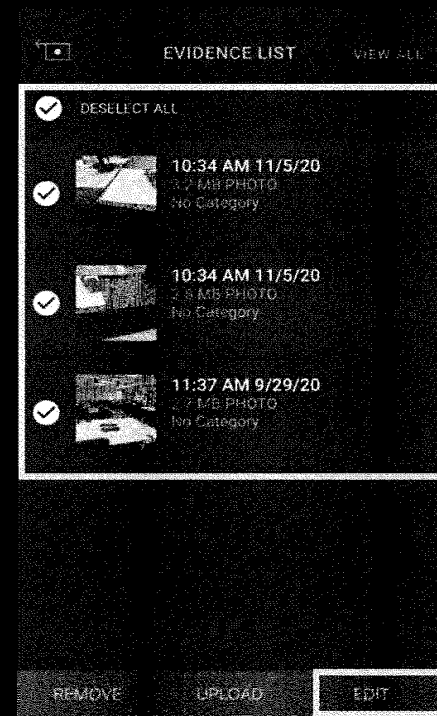

ADD METADATA

AXON CAPTURE - BULK EDIT



Step 7a

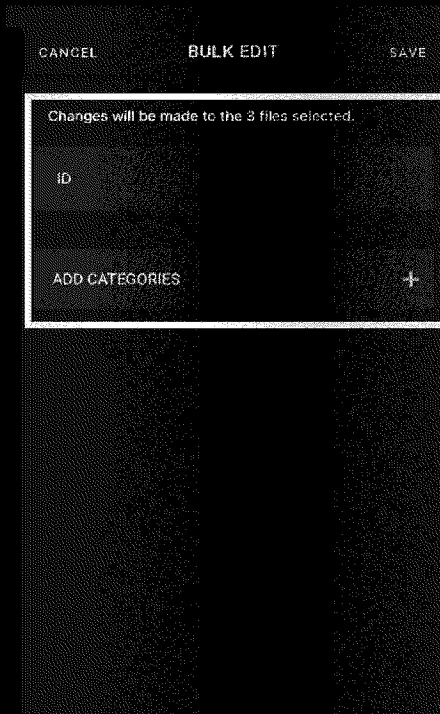

TAP TO ADD METADATA



Step 8a

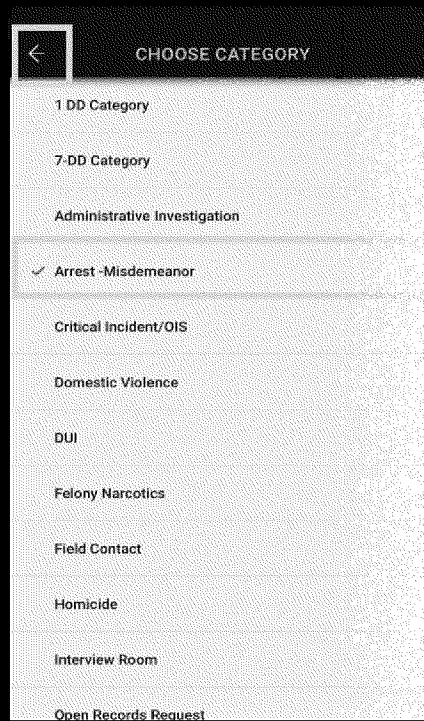

SELECT CATEGORY



Step 9a

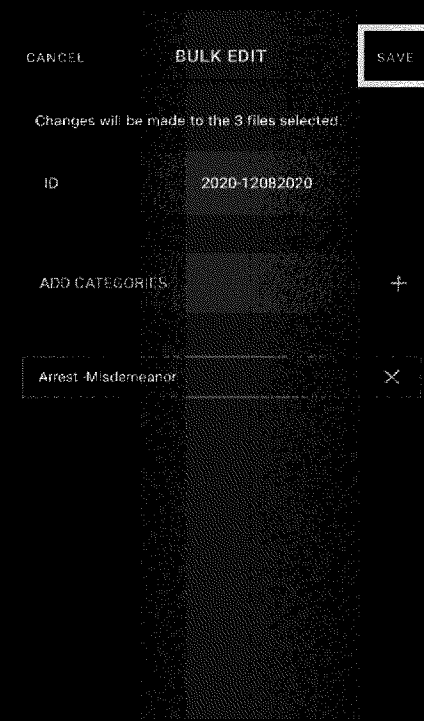

TAP SAVE

AXON CAPTURE - BULK EDIT



Step 10a

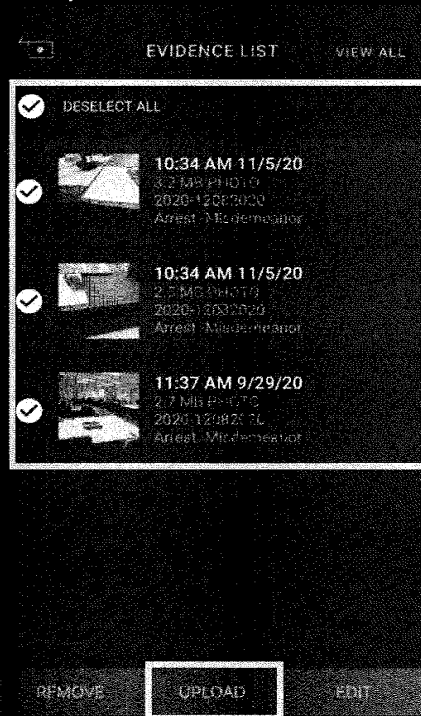

SELECT EVIDENCE & UPLOAD



Step 11a

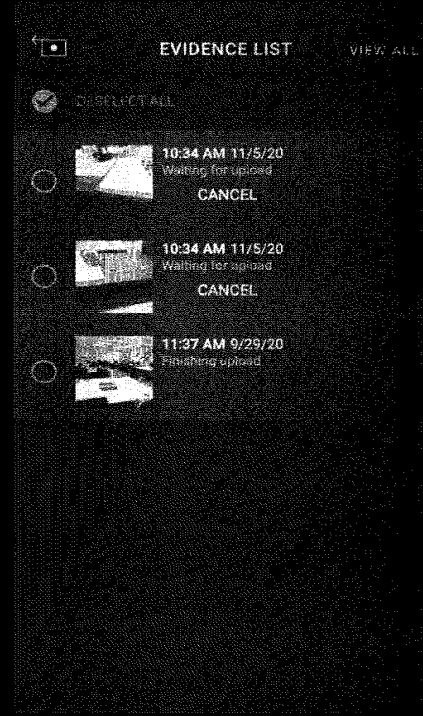

EVIDENCE WILL UPLOAD

AXON CITIZEN

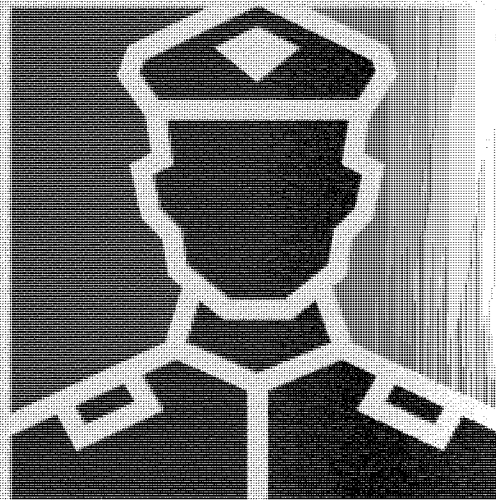

AXON CITIZEN



Step 1



Step 2

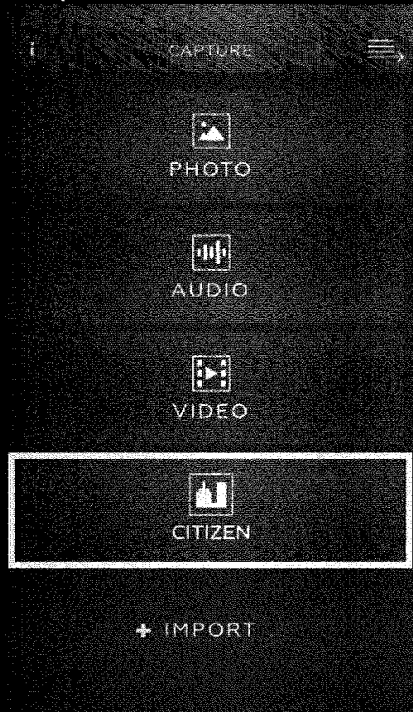

Step 3a

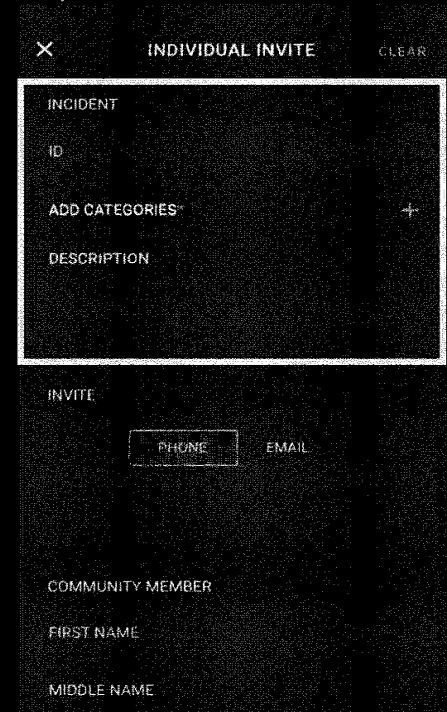

ENTER AXON CAPTURE APP



TAP CITIZEN



FILL OUT REQUIRED INFORMATION

AXON CITIZEN



Step 3b

× INDIVIDUAL INVITE CLEAR

INCIDENT

ID

ADD CATEGORIES* +

DESCRIPTION

INVITE

PHONE EMAIL

COMMUNITY MEMBER

FIRST NAME

MIDDLE NAME

Step 3c

× INDIVIDUAL INVITE CLEAR

INCIDENT

ID

ADD CATEGORIES* +

DESCRIPTION

INVITE

PHONE EMAIL

EMAIL

COMMUNITY MEMBER

FIRST NAME

MIDDLE NAME

Step 3d

× INDIVIDUAL INVITE CLEAR

INVITE

PHONE EMAIL

EMAIL

COMMUNITY MEMBER

FIRST NAME

MIDDLE NAME

LAST NAME

DATE OF BIRTH

SEND

SELECT PHONE OR EMAIL



ENTER PHONE# OR EMAIL



FILL OUT REQUIRED INFORMATION

AXON CITIZEN



Step 4

× INDIVIDUAL INVITE CLEAR

INVITE

PHONE EMAIL

EMAIL

COMMUNITY MEMBER

FIRST NAME

MIDDLE NAME

LAST NAME

DATE OF BIRTH

TAP SEND



Step 5

The invite has been sent

TAP OK OR ANOTHER INVITE



Step 6

< @ +1 (833) 762-9163

Today 2:03 PM

C. Foster requests evidence from you for the Professional Services. Click this link to view your request and submit evidence:
<https://pso.evidence.com/axon/citizen/share/j3hlsKl>

For questions, contact the Professional Services with ID: 2020-120220

CITIZEN RECEIVES A LINK

AXON CITIZEN



Step 7

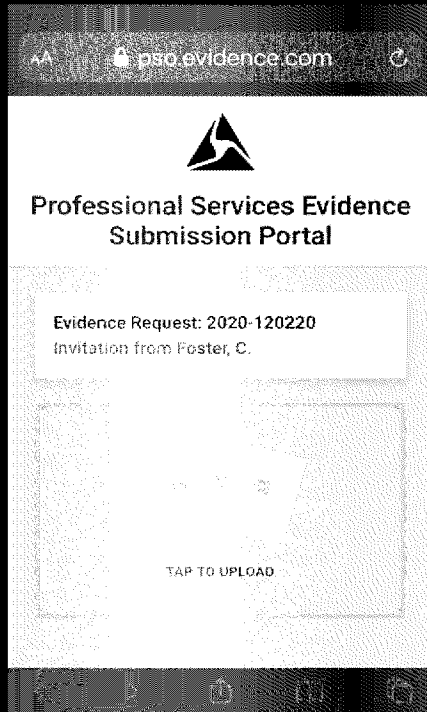

CITIZEN TAPS UPLOAD

Step 8

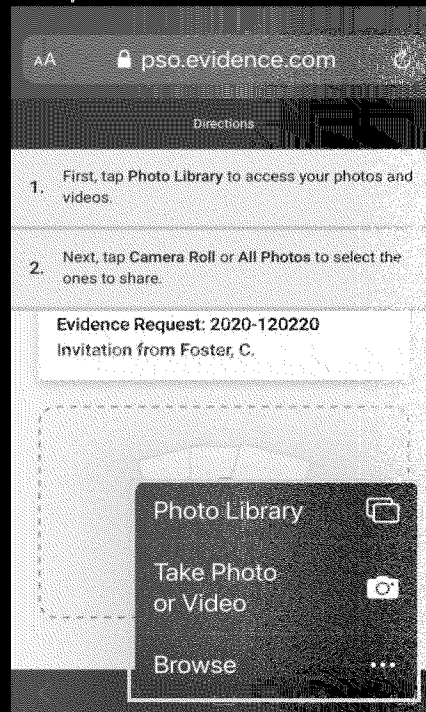

CITIZEN ENTERS LIBRARY

Step 9



CITIZEN SELECTS/ADDS EVIDENCE

AXON CITIZEN



Step 10

ps.evidence.com

970B6F73-5R35-4C02-A8BE-955 X

38FF855BD.jpeg

ADD MORE

By selecting 'Submit', I agree that these files are relevant to the incident. **SUBMIT**

[PRIVACY POLICY](#) [TERMS OF USE](#)

IF NEEDED ADD MORE EVIDENCE

Step 11

ps.evidence.com

Professional Services Evidence Submission Portal

Evidence Request: 2020-120220
Invitation from Foster, C.

2E09EFF2-EA27-4D89-A72F-A7E X

516987822.jpeg

Add an optional caption

B003B663-2A44-4546-A9A8-A9 X

By selecting 'Submit', I agree that these files are relevant to the incident. **SUBMIT**

CITIZEN SUBMITS

Step 12

ps.evidence.com

Professional Services Evidence Submission Portal

Thank you

Your files have been submitted

[PRIVACY POLICY](#) [TERMS OF USE](#)

CONFIRMATION

AXON CITIZEN



**EVIDENCE WILL UPLOAD
DIRECTLY INTO AXON
EVIDENCE ACCOUNT TO BE
TRIAGED OR VIEWED BY
AUTHORIZED USER**

AXON VIEW XL

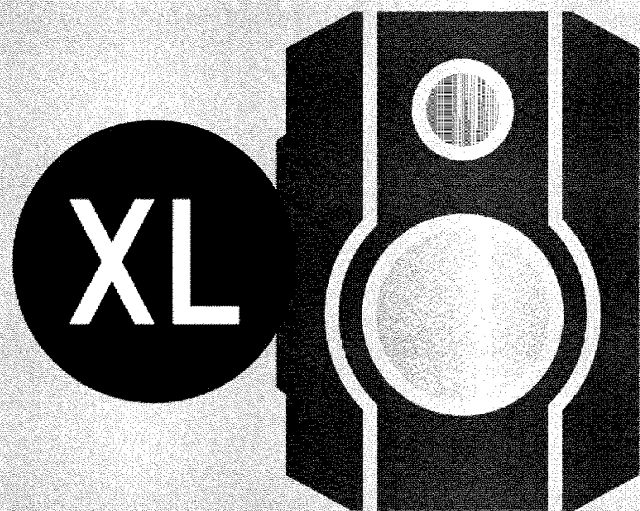

AXON VIEW XL



Step 1

AGENCY LOOKUP
Please enter your agency's evidence.com URL.

ATF.US

CONTINUE

Step 2

Professional Services
ps0.evidence.com

USERNAME
cfoster

PASSWORD
.....

SIGN IN

Forgot Password?

ENTER VIEW XL AND ENTER YOUR AGENCY



ENTER AXON EVIDENCE USERNAME
AND PASSWORD

AXON VIEW XL



Step 3

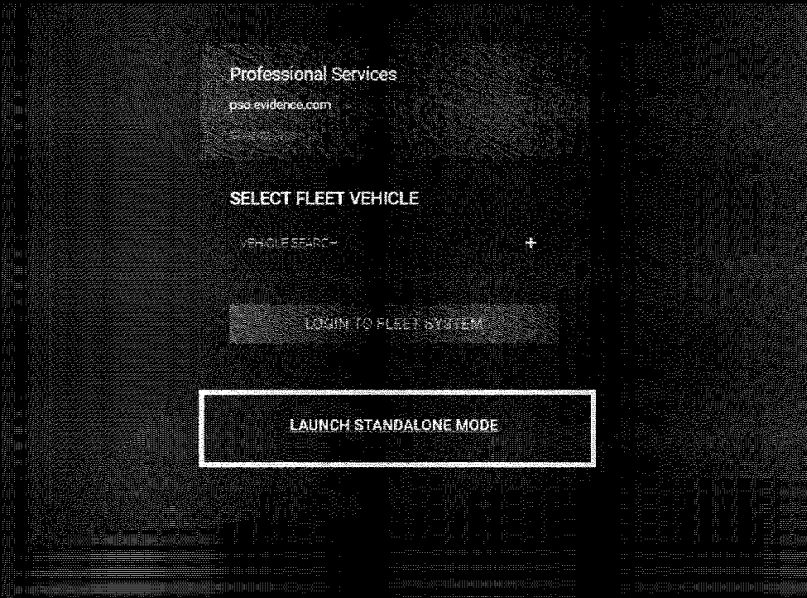

LAUNCH STANDALONE MODE

Step 4

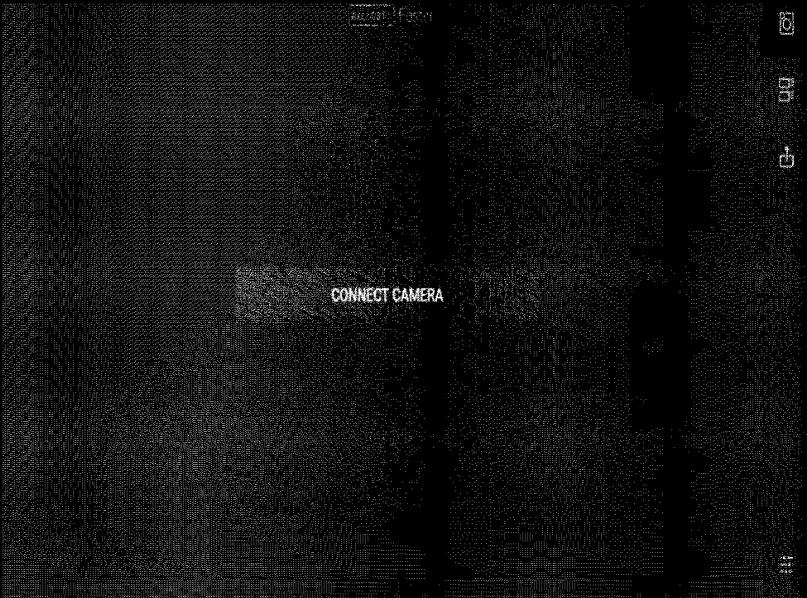

CONNECT CAMERA



AXON VIEW XL - SETTINGS



Step 1

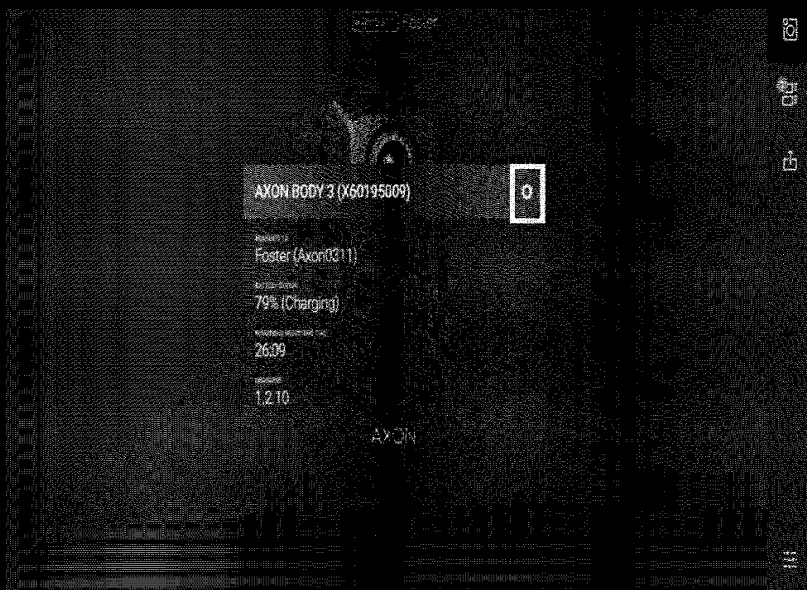

CLICK SETTINGS ICON



Step 2

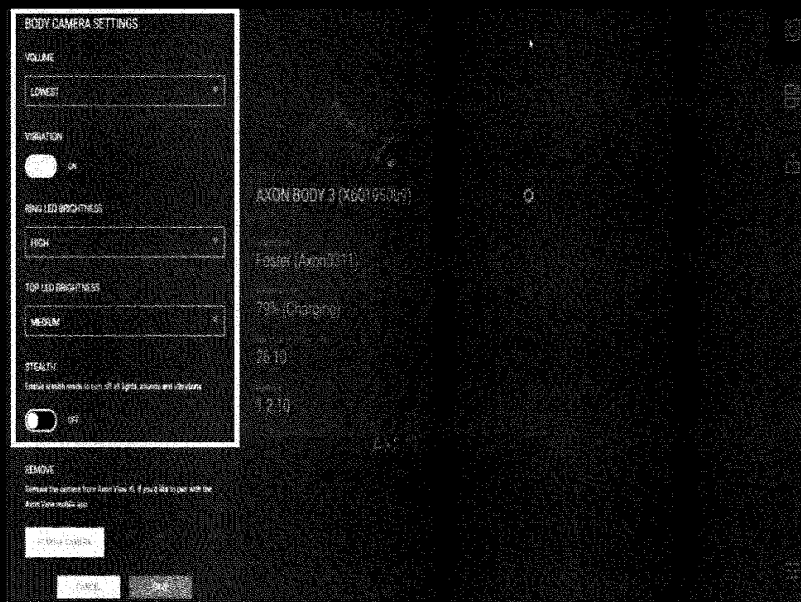

CHANGE AB3 SETTINGS

USING AXON VIEW XL - METADATA



Step 6

A screenshot of the Axon View XL interface showing metadata for a device. The device name is "AXON BODY 3 (X603991NS)". The user is identified as "Mco, Brian (0210)". The device status is "65% (Charging)". The recording time is "23:43". The date and time are "1.11.38". The interface includes a top bar with the user's name and ID, a central panel with device details, and a right-hand sidebar with various icons. The background is dark with a grid pattern.

0210 Mco

AXON BODY 3 (X603991NS)

ASSIGNED TO
Mco, Brian (0210)

REASON UNASSIGN

BATTERY STATUS
65% (Charging)

RECORDING TIME
23:43

DATE/TIME
1.11.38

CLICK ON REVIEW TAB

USING AXON VIEW XL - METADATA



Step 7

1 INCIDENT REQUIRES REVIEW

The screenshot displays the Axon View XL interface. On the left, a video player shows a hallway scene with a timestamp of 2019-08-19 18:31:08 and camera ID AXON-BODY 3 XG0195009. A progress bar at the bottom of the video player indicates 0:00 / 0:36. On the right, a metadata form is open, showing the incident ID 2019-123456, the title 'Axon ABS Test', and the category 'Use of Force'. The form includes checkboxes for 'PRIORITY' and 'UPLOAD', and a 'SUBMIT' button. On the far right, there are icons for camera view, list view, and share.

ADD ID, TITLE, AND CATEGORY

USING AXON VIEW XL - METADATA



Step 8

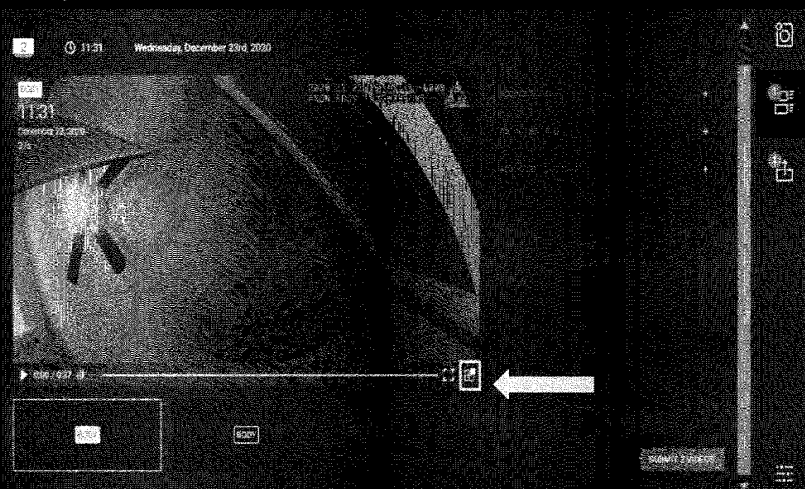

CLICK REMOVE FROM INCIDENT ICON

Step 9

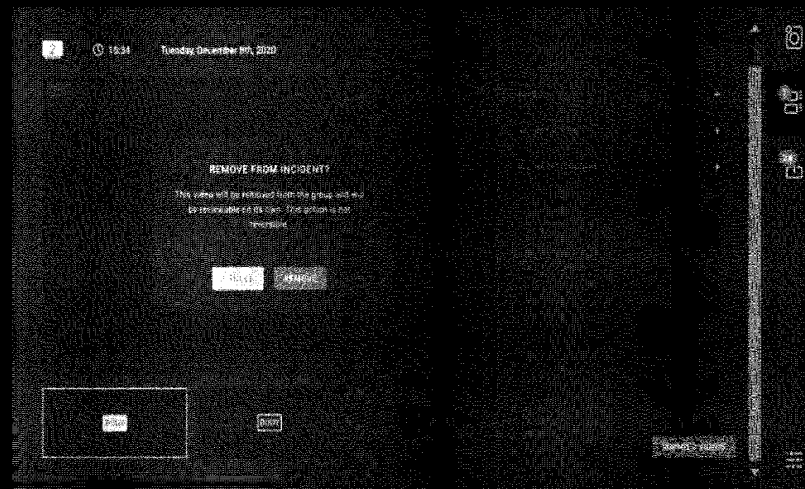

CLICK REMOVE TO SEPARATE VIDEOS

SEPARATE VIDEOS TO APPLY DIFFERENT METADATA

USING AXON VIEW XL - UPLOAD



Step 10

1 INCIDENT REQUIRES REVIEW

The screenshot displays the Axon View XL interface. On the left, a video player shows a hallway scene with a timestamp of 2019-08-19 18:31:08 and 'AXON BODY 3 X60195009'. On the right, a metadata panel shows '2019-123456', 'Axon ABS Test', and '2020-01-01 00:00:00'. At the bottom right, a 'PRIORITY UPLOAD' button is highlighted with a white rectangular box, and a 'SUBMIT' button is visible next to it. The interface also includes a search bar at the top right and a '1 INCIDENT REQUIRES REVIEW' notification at the top left.

SELECT PRIORITY UPLOAD AND CLICK SUBMIT

USING AXON VIEW XL - UPLOAD



Step 10a

UPLOAD STATUS

1 VIDEOS QUEUED 0 VIDEOS UP LOADING

BODY

10:38

September 16, 2019

38s

TITLE: Axon AB3 Test

ID: 2019-123456

Use of Force

Uploading 20190916 10:38

THE UPLOAD TAB WILL SHOW AB3 VIDEO EVIDENCE
QUEUED FOR AND UPLOADING TO AXON EVIDENCE

USING AXON VIEW XL - UPLOAD



Step 10b

THE UPLOAD TAB WILL SHOW AB3 VIDEO EVIDENCE
QUEUED FOR AND UPLOADING TO AXON EVIDENCE

EVIDENCE SYNC

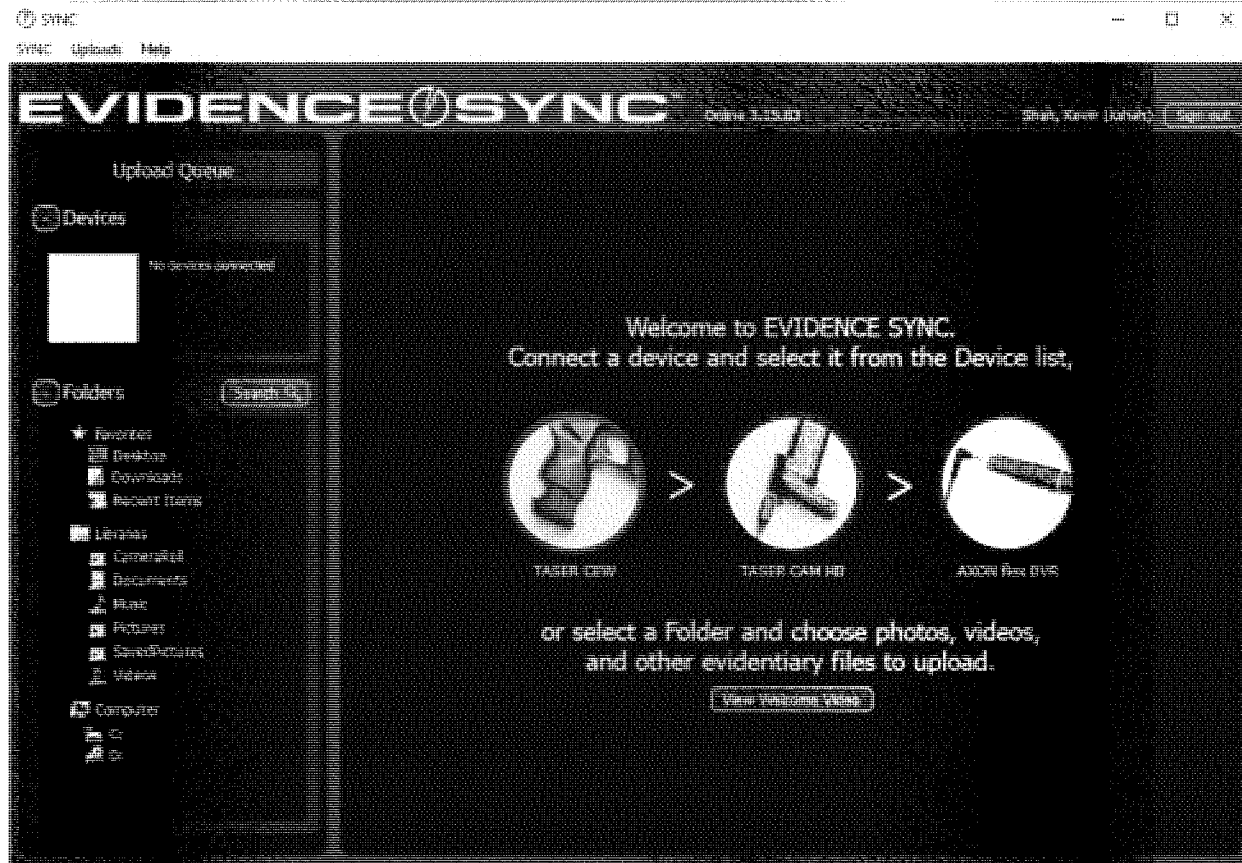

MODES - EVIDENCE SYNC



Evidence Sync can be configured in three operating modes:

1. **ONLINE:** Allows officers to view, add meta-data and upload Axon videos to Evidence.com
2. **MDT:** Allows officers to view and add metadata to videos, but restricts uploading videos to Evidence.com
3. **OFFLINE:** Allows officers to download videos to a desktop, but restricts adding metadata and uploading videos to Evidence.com

CONNECTING - EVIDENCE SYNC

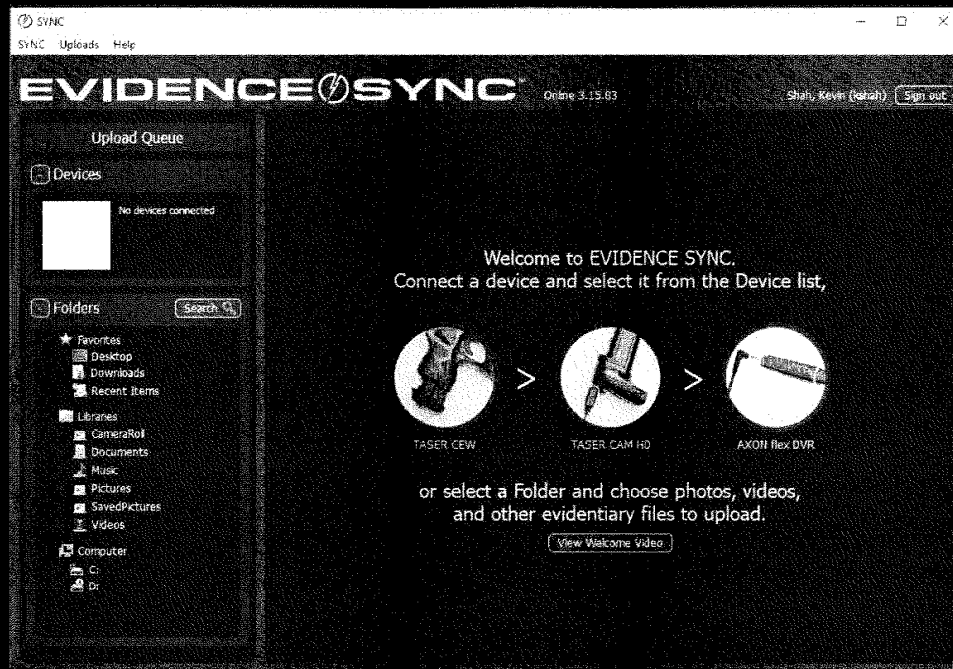

- Plug the charging cable into the back of the camera
- Connect the USB end into the USB port of your computer.

LOG IN - EVIDENCE SYNC



Enter your agency to sign in

.evidence.com

Enter Agency – ATF.US



User

Password

[Forgot Password](#)

[Re-enter Agency](#)

REVIEWING VIDEOS - EVIDENCE SYNC

The screenshot displays the Evidence Sync web application interface. The top navigation bar includes the SYNC logo, 'SYNC Uploads Help', and the user 'Shah, Kevin (kshah)' with a 'Sign out' button. The main content area is divided into three sections:

- Upload Queue:** Shows two devices with their respective images, IDs, names, and firmware versions, each with an 'Upload All' button.
 - Device 1: X83002365, Lin, Frank (lin123), Firmware: 1.14.1
 - Device 2: X81208680, Shah, Kevin (kshah), Firmware: 1.11.16
- Video List:** Features a filter section with 'Filters: OFF', 'From: 10:00 3 January 2018', 'To: 11:00 3 January 2018', and 'Status: All'. Below is a table of video entries.
- Device Settings:** A section for configuring device settings, currently empty.

Title	Timestamp	Duration	Status
Axon Flex 2 Video 2018-01-03 102018	3 Jan 2018 10:20:18	00:00:54	On device
Axon Flex 2 Video 2018-01-03 102113	3 Jan 2018 10:21:13	00:00:19	On device
Axon Flex 2 Video 2018-01-03 102200	3 Jan 2018 10:22:00	00:00:54	On device

After logging in, the home page will be visible. From here, the Video List and Device Settings will be visible.

EVIDENCE SYNC

Evidence Sync software allows you to use your computer to upload all evidence to Evidence.com.

The screenshot displays the Evidence Sync web application interface. At the top, the title "EVIDENCE SYNC" is prominent, along with the user's name "Shah, Kevin (kshah)" and a "Sign out" button. The interface is divided into several sections:

- Upload Queue:** Lists connected devices. Two devices are shown:
 - Device 1: ID X83002365, User Lin, Frank (lin123), Firmware 1.14.1. An "Upload All" button is present.
 - Device 2: ID X81208280, User Shah, Kevin (kshah), Firmware 1.11.16. An "Upload All" button is present.
- Folders:** A sidebar menu for file selection, including Favorites (Desktop, Downloads, Recent Items) and Libraries (CameraRoll, Documents, Music, Pictures, SavedPictures, Videos, Computer).
- Video List:** A table of uploaded videos with filters for time and status.

Title	Timestamp	Duration	Status
Axon Flex 2 Video 2018-01-03 102018	3 Jan 2018 10:20:18	00:00:54	On device
Axon Flex 2 Video 2018-01-03 102113	3 Jan 2018 10:21:13	00:00:19	On device
Axon Flex 2 Video 2018-01-03 102200	3 Jan 2018 10:22:00	00:00:54	On device
- Device Settings:** A section for configuring device-specific settings.

At the bottom, a "View Uploaded" button and a "Click the checkbox next to your video to select it for upload." instruction are visible. A video player preview shows a video titled "Axon Flex 2 Video 2018-01-03 102018" with a "here to play" button.

PLAYBACK VIDEOS – EVIDENCE SYNC

The screenshot displays the EVIDENCE SYNC web application interface. At the top, the title "EVIDENCE SYNC" is prominent, along with the user's name "Shah, Kevin (kshah)" and a "Sign out" button. The interface is divided into several sections:

- Upload Queue:** Shows a device "X83C02365" with details "Ln, Frank (fin123)" and "Firmware: 1.14.1", and an "Upload All" button.
- Folders:** A sidebar menu with "Favorites" (Desktop, Downloads, Recent Items) and "Libraries" (CameraRoll, Documents, Music, Pictures, SavedPictures, Videos).
- Video List:** A table with columns for Title, Timestamp, Duration, and Status. It lists three "Axon Flex 2 Video" entries from January 3, 2018.
- Device Settings:** A section for configuring device parameters.
- Playback Controls:** A video player at the bottom showing a play button and a "here to play" label.

Below the video list, there is a "View Uploaded" button and a note: "Click the checkbox next to your video to select it for upload." The first video in the list has its checkbox selected.

Title	Timestamp	Duration	Status
<input checked="" type="checkbox"/> Axon Flex 2 Video 2018-01-03 102018	3 Jan 2018 10:20:18	00:00:54	On device
<input type="checkbox"/> Axon Flex 2 Video 2018-01-03 102113	3 Jan 2018 10:21:13	00:00:19	On device
<input type="checkbox"/> Axon Flex 2 Video 2018-01-03 102200	3 Jan 2018 10:22:00	00:00:54	On device

PLAYBACK VIDEOS – EVIDENCE SYNC

The screenshot displays the Evidence Sync web application interface. At the top, the logo "EVIDENCE SYNC" is visible along with the version "Online 3.15.83" and the user "Shah, Kevin (kshah)" with a "Sign out" button. The main content area is divided into two sections: "Upload Queue" on the left and a video player on the right.

Upload Queue:

- Devices:** A list of devices with a search icon. One device is shown: X83002365, Lin, Frank (lin123), Firmware: 1.14.1, with an "Upload All" button.
- Folders:** A list of folders with a search icon. The folders listed are: Favorites, Desktop, Downloads, Recent Items, Libraries, CameraRoll, Documents, Music, Pictures, SavedPictures, Videos, and Computer. Under Computer, drives C: and D: are listed.

Video Player:

- The video shows a close-up of a device, likely an Axon Flex 2, with a timestamp "2018-01-03 13:20:14Z" and device ID "AXON FLEX 2 X83002365".
- The video player includes a progress bar showing "00:00:00" and "00:00:54".
- Below the video, the title "Title: Axon Flex 2 Video 2018-01-03 102018" and "Categories: ID:" are displayed.

PLAYBACK VIDEOS – EVIDENCE SYNC

The screenshot displays the EVIDENCE SYNC web application interface. The top navigation bar includes the application name "EVIDENCE SYNC", the version "Online 3.15.83", the user name "Shah, Kevin (kshah)", and a "Sign out" button. The main interface is divided into three sections: "Upload Queue", "Video List", and "Device Settings".

Upload Queue: This section contains a "Devices" list with one device entry: "X83C02365" (Lin, Frank (fin123)) with firmware "1.14.1" and an "Upload All" button. Below this is a "Folders" section with a search bar and a list of system folders: Favorites, Desktop, Downloads, Recent Items, Libraries (CameraRoll, Documents, Music, Pictures, SavedPictures, Videos), and Computer (C:, D:).

Video List: This section features a table with columns for "Title", "Bulk Edit ID", "Bulk Edit Categories", and "Bulk Edit Assignee". A single video entry is listed: "Video 2018-01-03 1020:8" with corresponding bulk edit options.

Device Settings: This section is currently empty.

At the bottom of the interface, there are three buttons: "Save", "Upload", and "Upload to Case".

AXON EVIDENCE

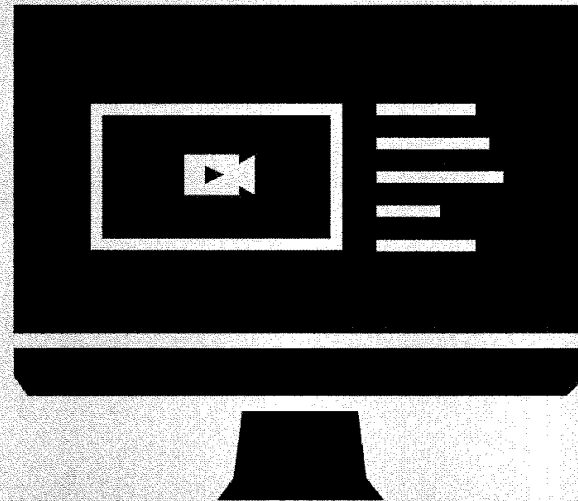

[HTTPS://ATFTEST.US.EVIDENCE.COM](https://atftest.us.evidence.com)



ATF.US.EVIDENCE.COM



1. Logging into Evidence.com and User Dashboard (SSO)
2. Evidence Location
 1. My Evidence (Can See only evidence owned by you)
3. Evidence Review Page
 1. Metadata Entry
 2. Video Review Controls
 3. Redaction Assistant
 4. Access Control List
4. Citizen Invites
5. Import Evidence
6. Cases
 1. Case Creation
 2. Case Access Control List

Q & A

Group Supervisor Training

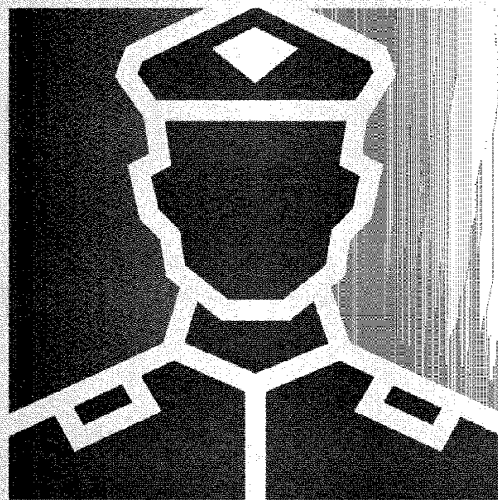

ATF.US.EVIDENCE.COM



1. User Search
2. Search For Evidence - Group Level Access
 1. Advanced Search Filters
 2. Reassigning Evidence
3. Evidence Review Page
 1. Reassigning Evidence
 2. Multi-Cam Playback
 3. Access Control List - Individual and Group Access

Q & A

SAC/Admin/Trainer Training

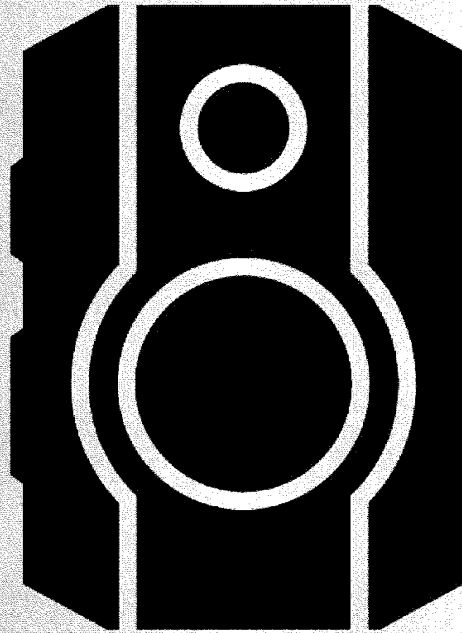

ATF.US.EVIDENCE.COM



1. Evidence Search - Division Level Access
2. Access Control List
 1. Restricting Videos
3. Inventory Page
 1. Searching for Devices
 2. Assigning and Reassigning Devices

Q & A

(b) (5)

(b) (5)

(b) (5)

(b) (5)

(b) (5)

(b) (5)

(b) (5)

(b) (5)

(b) (5)

(b) (5)

(b) (5)

(b) (5)

(b) (5)

(b) (5)

(b) (5)

(b) (5)

(b) (5)

(b) (5)

(b) (5)

(b) (5)

(b) (5)

APPENDIX

A

**Department of Justice Policy on Use of
Body-Worn Cameras by Federally
Deputized Task**



U.S. Department of Justice
Washington, D.C.

USE OF BODY-WORN CAMERAS BY FEDERALLY DEPUTIZED TASK FORCE OFFICERS

The Department of Justice (Department or DOJ) permits the use of body worn cameras (BWCs) by task force officers (TFOs) on federal task forces. This policy provides the parameters for the use of BWCs by TFOs to the extent that a state or local law enforcement agency¹ requires their use by its officers during federal task force operations. DOJ law enforcement agencies may issue internal standard operating procedures to implement TFO use of BWCs consistent with this policy.² For purposes of this policy, the term, "TFO BWC recordings," refers to audio and video recordings and associated metadata from TFO BWCs made while the TFO is working under federal authority, including state and local warrants adopted by a federal agency.

I. BACKGROUND

The Department of Justice partners with state and local law enforcement agencies throughout the nation on joint task forces. This relationship is vitally important to the Department and its mission to protect our communities. Several of these participating state and local agencies have implemented internal policies mandating the use of BWCs and have requested that their officers wear BWCs while conducting planned arrests and

¹ This policy applies equally to tribal and territorial law enforcement agencies.

² This policy provides Department components with internal direction. It is not intended to, does not, and may not be relied upon to create any substantive or procedural rights enforceable at law by any party in any civil or criminal matter.

searches during federal task force operations. Some state and local agencies, however, do not equip their officers with BWCs. To the extent state and local law enforcement agencies mandate BWCs for TFOs while engaged in federal task force operations, the Department will permit federally deputized TFOs from those agencies to use their BWCs under the following circumstances.

II. USE OF BODY WORN CAMERAS DURING FEDERAL TASK FORCE OPERATIONS

Unless subject to specific exceptions below, TFOs employed by a law enforcement agency that mandates the use of BWCs on federal task forces may wear and activate their recording equipment for the purpose of recording their actions during task operations³ only during: (1) a planned attempt to serve an arrest warrant or other planned arrest; or, (2) the execution of a search warrant.⁴ TFOs are authorized to activate their BWCs upon approaching a subject or premises, and must deactivate their BWCs when the scene is secured as determined by the federal supervisor on the scene as designated by the sponsoring federal agency. For purposes of this policy, the term “secured” means that the scene is safe and under law enforcement control. In the event circumstances arise requiring additional law enforcement assistance to secure the scene, the TFO will end BWC recording when relieved from the scene by another law enforcement officer. TFOs are prohibited from recording: (1) undercover personnel; (2) confidential informants or confidential sources; (3) on-scene witness interviews prior to or after the operation; (4)

³ TFOs are authorized to wear and activate their recording equipment in accordance with this policy anywhere they are authorized to act as a police or peace officer under state, local, territorial or tribal law.

⁴ For the execution of a search warrant, BWCs should not be used for searches of property lawfully in government custody or control, or a search to obtain digital or electronic records executed by a third party, such as an electronic service provider or custodian of electronic records.

personnel using specialized or sensitive investigative techniques or equipment; or (5) on-scene actions by any non-law enforcement persons who are assisting law enforcement personnel prior to or after the operation. TFOs are prohibited from activating their BWC if the TFO is using specialized or sensitive investigative techniques, operating in a sensitive area, or working in an undercover or covert status on behalf of the federal task force or federal agency as determined by the federal agency sponsoring the task force. Subject to the discretion of the federal agency sponsoring the task force, TFOs generally shall not use their BWCs to record any activities related to investigations involving public corruption, medical facilities, national security, or other sensitive investigations. The Department's policy of permitting the limited use of BWCs on task forces does not apply to highly specialized or sensitive operations or groups as determined by the federal agency sponsoring the task force.

III. STORAGE OF TASK FORCE OFFICER BODY WORN CAMERA RECORDINGS IN FEDERAL TASK FORCE OPERATIONS

The TFO activating a BWC during federal task force operations is responsible for downloading, or having his/her parent agency personnel download, the resulting TFO BWC recordings. Once the TFO BWC recording is downloaded, it shall be placed onto external media (e.g., DVD, hard drive, etc.), or another mutually agreeable delivery mechanism, and promptly provided to the federal task force. The TFO parent agency will provide to the sponsoring federal agency a recording that qualifies as a "duplicate" under Federal Rule of Evidence 1001(e).⁵ The federal agency sponsoring the task force shall

⁵ Under Fed. R. Evid. 1001(e), "[a] 'duplicate' means a counterpart produced by a mechanical, photographic, chemical, electronic, or other equivalent process or technique that accurately reproduces the original."

maintain the TFO BWC recording from the TFO as appropriate in the federal agency's files.

IV. FEDERAL RECORDS

All TFO BWC recordings made during federal task force operations, including such recordings retained by the TFO's parent agency and/or in the possession of any third party engaged by the parent agency to store or process BWC recordings, shall be deemed federal records of the Department and the federal agency sponsoring the task force pursuant to the Federal Records Act. In all circumstances, TFO BWC recordings shall be treated as law enforcement sensitive information, the premature disclosure of which could reasonably be expected to interfere with enforcement proceedings, and as potential evidence in a federal investigation subject to applicable federal laws, rules, and policy concerning any disclosure or dissemination; and therefore deemed privileged absent appropriate redaction prior to disclosure or dissemination. Nothing in this policy shall be deemed to provide a right of public access to TFO BWC recordings. TFO BWC recordings are controlled by, and the property of, the Department and will be retained and managed by the federal agency sponsoring the task force. The federal agency sponsoring the task force is responsible for considering requests to release TFO BWC recordings. These records cannot be disseminated without the written permission of the Department, subject to the following exceptions:

A. Internal Dissemination

The TFO's parent agency is authorized to use TFO BWC recordings for internal investigations of its personnel consistent with the parent agency's policies and

procedures, but may not disseminate the BWC recording outside the parent agency or for public release without the written permission of the Department. The parent agency shall provide written notification to the sponsoring federal agency prior to any internal review.

B. Expedited Public Release

If TFO BWC recording(s) depict conduct committed solely by a TFO resulting in serious bodily injury or death of another, the TFO's parent agency shall notify the sponsoring federal agency⁶ and the United States Attorney as early as possible if it desires to publicly release the TFO's BWC recording(s). The sponsoring federal agency and the United States Attorney will expeditiously review the recording(s) and provide official concurrence with public release as soon as practical, unless there are specific and compelling circumstances justifying an objection to public release that cannot be resolved by redaction or other means. Upon official concurrence, the TFO's parent agency may immediately release the recording(s) with any agreed-upon redactions, giving as much advance notice as possible to the sponsoring federal agency and United States Attorney as to the time and manner of its release.

⁶ The notification may be to the Special Agent in Charge (SAC) of the federal agency sponsoring the task force or, in the case of United States Marshals Service-led task forces, the local United States Marshal and the Assistant Director (AD) / Investigative Operations Division (IOD) of the U.S. Marshals Service, and any discussions, negotiations, and concurrence may be made by the SAC or, in the case of the US Marshals Service, the local US Marshal and AD/IOD, after appropriate consultation within their agency.

V. MEMORIALIZATION

Subject to the guidance set forth in this policy, the SAC of the sponsoring federal law enforcement agency or, in the case of United States Marshals Service-led task forces, the Assistant Director of the Investigative Operations Division, is responsible for memorializing any agreement with a state and local law enforcement agency on the use of BWCs by federally deputized TFOs during federal task force operations. Upon notification to the United States Attorney, the SAC or AD/IOD shall execute a Memorandum of Understanding (MOU), or addendum to a preexisting MOU, prior to use of BWCs by TFOs that sets forth the details for the use of BWCs by TFOs on the task force consistent with this policy. Prior to entering into any agreement, the TFO's parent agency shall provide to the federal agency sponsoring the task force the details regarding the BWC system and cameras, including the details of any system protections, to the satisfaction of the federal agency, and any state or local policies or laws applicable to the TFO's use of BWCs, including any retention policies. This MOU shall make clear that TFO BWC recordings, including such recordings residing in the state/local agency's BWC system or other copies retained by the agency and/or in the possession of any third party engaged by the agency to store or process BWC recordings, are deemed to be federal records, subject to federal retention and information access laws, regulations, policies, and procedures. The federal agency sponsoring the task force will ensure that all participating agencies are informed of which participating agencies, if any, mandate BWC use by their respective TFOs, and provide all participating agencies with this policy.

APPENDIX B
Acronyms

ASAC	Assistant Special Agent in Charge
ATF	Bureau of Alcohol, Tobacco, Firearms and Explosives
BWC	Body-Worn Camera
CC	Office of Chief Counsel
CS	Confidential Source
DAD	Deputy Assistant Director
DFB	Digital Forensics Branch
DOJ	Department of Justice
FMS	Field Management Staff
FO	Office of Field Operations
FRO	Force Review Office
KEP	Kinetic Energy Projectile
OPRSO	Office of Professional Responsibility and Security Operations
OSII	Office of Strategic Intelligence and Information
OST	Office of Science and Technology
SA	Special Agent
SAC	Special Agent in Charge
SES	Senior Executive Service
SOD	Special Operations Division
SOP	Standard Operating Procedure
SSA	Supervisory Special Agent
SSD	Solid State Drives
TFO	Task Force Officer
TOB	Technical Operations Branch
UC	Undercover
USAO	United States Attorney's Office

(b) (5)

(b) (5)

(b) (5)

(b) (5)

(b) (5)

(b) (5)

(b) (5)

(b) (5)

(b) (5)

(b) (5)

(b) (5)

(b) (5)

(b) (5)

(b) (5)

(b) (5)

(b) (5)



U.S. Department of Justice
Office of the Deputy Attorney General

The Deputy Attorney General

Washington, D.C. 20530
June 7, 2021

MEMORANDUM FOR ACTING DIRECTOR, BUREAU OF ALCOHOL, TOBACCO,
 FIREARMS & EXPLOSIVES
 ACTING ADMINISTRATOR, DRUG ENFORCEMENT
 ADMINISTRATION
 DIRECTOR, FEDERAL BUREAU OF INVESTIGATION
 DIRECTOR, UNITED STATES MARSHALS SERVICE
 ASSISTANT ATTORNEY GENERAL FOR
 ADMINISTRATION
 EXECUTIVE OFFICE FOR UNITED STATES ATTORNEYS

FROM: THE DEPUTY ATTORNEY GENERAL *via M. M. M. M. M.*

SUBJECT: BODY-WORN CAMERA POLICY

The Department of Justice recognizes that transparency and accountability in law enforcement operations build trust with the communities we serve. Although the Department’s law enforcement components do not regularly conduct patrols or routinely engage with the public in response to emergency calls, there are circumstances where the Department’s agents encounter the public during pre-planned law enforcement operations. The Department is committed to the use of body-worn cameras (BWCs) by the Department’s law enforcement agents in such circumstances.

In October 2020, the Department announced a policy that permits state and local officers on Department of Justice Task Forces to wear and activate BWCs when the use of force is possible – while serving arrest warrants, executing other planned arrest operations, and during the execution of search warrants. Today, based on recommendations from the Department’s law enforcement components, I am directing the Acting Director of the Bureau of Alcohol, Tobacco, Firearms & Explosives; the Acting Administrator of the Drug Enforcement Administration; the Director of the Federal Bureau of Investigation, and the Director of the United States Marshals Service to develop and submit for review, within 30 days, component BWC policies that require agents to wear and activate BWC recording equipment for purposes of recording their actions during: (1) a pre-planned attempt to serve an arrest warrant or other pre-planned arrest, including the apprehension of fugitives sought on state and local warrants; or (2) the execution of a search or seizure warrant or order.

Memorandum from the Deputy Attorney General
Subject: Body-Worn Camera Policy

Page 2

Each law enforcement component shall develop its policy and a phased implementation plan for compliance with the above directive no later than 30 days from the date of this memorandum, and shall designate a senior official with responsibility for implementation and oversight of its BWC policy. Each component also shall ensure immediately that partners serving on DOJ-sponsored task forces are aware of the current Department policy that permits state and local officers on DOJ task forces to wear and activate BWCs.

Each component's BWC policy shall include:

- the responsibilities for Department agents to carry, operate, maintain, and secure the equipment, including when to activate and deactivate BWCs;
- the type(s) of BWC equipment authorized for use;
- the duration of time and scope of the BWC footage preserved prior to its activation (i.e., buffering period);
- specialized or sensitive investigative techniques or equipment that may require different treatment under the BWC policy;
- procedures governing the collection, storage, access, retention, use, and dissemination of BWC recordings, consistent with applicable federal laws;
- procedures governing the use of BWCs by all members of Department-sponsored task forces; and
- procedures for the expedited public release of recordings in cases involving serious bodily injury or death.

In addition, as soon as practicable, each component shall:

- submit for the approval of the Department's Chief Privacy and Civil Liberties Officer a Privacy Impact Assessment of the component's planned use of BWCs and associated equipment prior to implementation of its BWC policy, and a plan for annual privacy reviews;
- consult with the Office of Records Management to ensure the component's BWC policy is fully compliant with all records-related laws, regulations, rules, policies, and guidance;
- work with the Justice Management Division to assess resource requirements to fully implement its BWC policy and build upon the resources allocated to the Department to support BWC usage in FY22; and
- design evaluation metrics that can be used to measure the impact of its BWC policy.

Memorandum from the Deputy Attorney General
Subject: Body-Worn Camera Policy

Page 3

Finally, within 90 days, the Executive Office for U.S. Attorneys should develop training for prosecutors regarding the use of BWC recordings as evidence, building on existing trainings related to the discovery implications of these recordings.

I am proud of the job performed by the Department's law enforcement agents, and I am confident that these policies will continue to engender the trust and confidence of the American people in the work of the Department of Justice.

APPENDIX F

Category	Description
ATF Special Agent BWC	Default category that should be selected for every SA BWC recording
ATF Task Force Officer (TFO) BWC	Default category that should be selected for every ATF TFO BWC recording
Use of Force – Shooting (ATF)	Selection for video that includes firearm discharge by a ATF employee
Use of Force – Shooting (TFO)	Selection for video that includes firearm discharge by a Task Force Officer
Use of Force – Other (ATF)	Selection for video that includes non-firearm use by an ATF employee (CEW, etc)
Use of Force – Other (TFO)	Selection for video that includes non-firearm use by a Task Force Officer (CEW, etc)
Use of Force – K9 Bite	Selection for video that includes a K9 bite
Serious Injury/Death to Personnel (ATF/TFO)	Selection for video that includes injury or death of either ATF employees or Task Force Officers
Serious Injury/Death to Subject	Selection for video that includes injury or death of the subject of pre-planned arrest warrant or pre-planned search warrant
Serious Injury/Death to Other	Selection for video that includes injury or death of another individual
Damage to Property (By ATF/TFO)	Selection for video that includes damage to non-ATF property caused by either ATF SA's or TFO's
Damage to ATF Property/Vehicle (by other)	Selection for video that includes damage to ATF property or vehicles by non-ATF employees or TFO's
Litigation	Selection for video that includes FOIA, Bivens, Touhy, torts, media releases

Category	Description
3 rd Party Individual	3 rd party individual or individuals not associated with the warrant
3 rd Party Vehicle/Tag	3 rd party vehicle or tag not associated with the warrant
Arrest Warrant	Contains execution of a pre-planned arrest warrant
Complaint (IAD, OPRSO)	Video that has been identified as relevant in a complaint against the ATF or an ATF employee
Evidence Seized (By ATF/TFO)	Includes evidence seized by ATF employees or TFO's
Exigent Review Request	DOJ policy exigent review applies
Investigation (IAD)	Identified as relevant in an internal investigation
Litigation-ATF Legal Counsel	Identified as relevant in litigation
Minor Individual	Includes a minor individual
OPRSO	Relevant to OPRSO
Search Warrant	Contains the execution of a pre-planned search warrant
Sensitive Investigative Techniques	Includes sensitive investigative techniques (TOB, EUP,SRT)
Source of Information, CS or UC	Includes a source of information, confidential source or under cover individual
Training (SOD)	Training exercise
ATF Vehicle/Tag	Includes an ATF vehicle or tag
Vehicle Involved Arrest	Includes a vehicle involved arrest
FFL Investigation	Includes evidence involving investigation of a Federal Firearms Licensee
Arson Investigation	Investigation of a suspected Arson
Category	Description
Explosives Investigation	Evidence involved in an explosive's investigation
TBD	
TBD	
TBD	
TBD	
TBD	

(b) (5)

(b) (5)

(b) (5)

(b) (5)

(b) (5)

(b) (5)

(b) (5)

(b) (5)

(b) (5)

(b) (5)

(b) (5)

(b) (5)

(b) (5)

(b) (5)

(b) (5)

(b) (5)

(b) (5)

(b) (5)

(b) (5)

To: (b) (6), (b) (7)(C)
From: (b) (6), (b) (7)(C)
Sent: Wed 8/11/2021 12:37:43 AM
Subject: RE: BWC PIA
ATF Axon Evidence PIA 08-10-2021.docx

Little progress - doing another edit on the file - DOJ has a new approver and we needed to make changes in a few areas.

The attached is what I've been working on - I incorporated all the comments, suggestions and corrections.

What I really need is a fresh pair of eyes - a critical set at that. I'll also be sending this back to legal and ISSO. Sorry this process is taking the time it is, ATF has not done PIAs in a number of years so the older versions I received to use as examples added confusion more than assistance.

If it helps here is a link to a PIA they just approved and shows what they are looking for.
(<https://www.justice.gov/opcl/page/file/1412716/download>)

V (b) (6)

-----Original Message-----

From: (b) (6), (b) (7)(C)
Sent: Tuesday, August 10, 2021 5:01 PM
To: (b) (6), (b) (7)(C)
Subject: BWC PIA

Good afternoon,

Any updates from OPCL?

ATF Senior Special Agent/Digital Evidence Management Systems Project Officer (b) (6), (b) (7)(C)

(b) (5)

(b) (5)

(b) (5)

(b) (5)

(b) (5)

(b) (5)

(b) (5)

(b) (5)

(b) (5)

(b) (5)

(b) (5)

(b) (5)

(b) (5)

(b) (5)

(b) (5)

(b) (5)

(b) (5)

To: (b) (6), (b) (7)(C) (b) (6), (b) (7)(C)
From: (b) (6), (b) (7)(C)
Sent: Wed 8/18/2021 4:32:51 PM
Subject: RE: Body Worn Camera Policy
ATF Policy BWC 8 17 21.docx
ATF - DEM - BWC - SOP - 21-08-14.docx

The attached DRAFT Standard Operating Procedure is for our Digital Evidence Management Branch which includes our TFO body-worn camera program. The ATF special agent BWC portion begins on page 39 for reference.

The DRAFT ATF Policy attached is also attached.

(b) (6), (b) (7)(C)
Alcohol, Tobacco, Firearms and Explosives
16009 N. 81st Street, Suite 100
Scottsdale, AZ 85260
Special Agent Project Officer-Digital Evidence Management
Technical Project Office
Special Operations Division
(b) (6), (b) (7)(C)

CONFIDENTIALITY NOTICE: E-mail may contain confidential information that is legally privileged. Do not read this e-mail if you are not the intended recipient.

This e-mail transmission, and any documents, files or previous e-mail messages attached to it may contain confidential information that is legally privileged. If you are not the intended recipient, or a person responsible for delivering it to the intended recipient, you are hereby notified that any disclosure, copying, distribution or use of any of the information contained in or attached to this transmission is **STRICTLY PROHIBITED**. If you have received this transmission in error, please immediately notify us by reply e-mail, by forwarding this to (b) (6), (b) (7)(C) or by telephone at (b) (6), (b) (7)(C) and destroy the original transmission and its attachments without reading or saving in any manner. Thank you.

From: (b) (6), (b) (7)(C)
Sent: Wednesday, August 18, 2021 8:17 AM
To: (b) (6), (b) (7)(C)
Cc: (b) (6), (b) (7)(C)
Subject: Re: Body Worn Camera Policy

Hi (b) (6), (b) (7)(C) We, that is (b) (6), (b) (7)(C) can send you our draft policy and SOPs. We begin a pilot program in our Detroit and Phoenix Field Divisions on 9/1.

The drafts haven't yet been cleared by our leadership or DOJ so, as I'm sure you can appreciate, please keep them close-hold.

On Aug 18, 2021, at 10:32 AM, (b) (6), (b) (7)(C) wrote:

(b) (6), (b) (7)(C)

Good morning! I'm circling back around to see what the status is of the ATF's body worn

camera policy and whether DS can get a copy of that policy. My agency is in a holding pattern while we observe how DOJ is rolling this out for its agencies, but we'd like to start reviewing the written policies. Anything would be greatly appreciated.

Many thanks,

(b) (6), (b) (7)

SSA (b) (6), (b) (7)(C)
Chief, Intelligence Liaison Division
Diplomatic Security Service
Office: (b) (6), (b) (7)(C)
Mobile (b) (6), (b) (7)(C)

SBU -LAW ENFORCEMENT

(b) (5)

(b) (5)

(b) (5)

(b) (5)

(b) (5)

(b) (5)

(b) (5)

(b) (5)

(b) (5)

(b) (5)

(b) (5)

(b) (5)

(b) (5)

(b) (5)

(b) (5)

(b) (5)

(b) (5)

(b) (5)

(b) (5)

(b) (5)

(b) (5)

(b) (5)

(b) (5)

(b) (5)

(b) (5)

(b) (5)

(b) (5)

(b) (5)

APPENDIX

A

**Department of Justice Policy on Use of
Body-Worn Cameras by Federally
Deputized Task**



U.S. Department of Justice
Washington, D.C.

USE OF BODY-WORN CAMERAS BY FEDERALLY DEPUTIZED TASK FORCE OFFICERS

The Department of Justice (Department or DOJ) permits the use of body worn cameras (BWCs) by task force officers (TFOs) on federal task forces. This policy provides the parameters for the use of BWCs by TFOs to the extent that a state or local law enforcement agency¹ requires their use by its officers during federal task force operations. DOJ law enforcement agencies may issue internal standard operating procedures to implement TFO use of BWCs consistent with this policy.² For purposes of this policy, the term, "TFO BWC recordings," refers to audio and video recordings and associated metadata from TFO BWCs made while the TFO is working under federal authority, including state and local warrants adopted by a federal agency.

I. BACKGROUND

The Department of Justice partners with state and local law enforcement agencies throughout the nation on joint task forces. This relationship is vitally important to the Department and its mission to protect our communities. Several of these participating state and local agencies have implemented internal policies mandating the use of BWCs and have requested that their officers wear BWCs while conducting planned arrests and

¹ This policy applies equally to tribal and territorial law enforcement agencies.

² This policy provides Department components with internal direction. It is not intended to, does not, and may not be relied upon to create any substantive or procedural rights enforceable at law by any party in any civil or criminal matter.

searches during federal task force operations. Some state and local agencies, however, do not equip their officers with BWCs. To the extent state and local law enforcement agencies mandate BWCs for TFOs while engaged in federal task force operations, the Department will permit federally deputized TFOs from those agencies to use their BWCs under the following circumstances.

II. USE OF BODY WORN CAMERAS DURING FEDERAL TASK FORCE OPERATIONS

Unless subject to specific exceptions below, TFOs employed by a law enforcement agency that mandates the use of BWCs on federal task forces may wear and activate their recording equipment for the purpose of recording their actions during task operations³ only during: (1) a planned attempt to serve an arrest warrant or other planned arrest; or, (2) the execution of a search warrant.⁴ TFOs are authorized to activate their BWCs upon approaching a subject or premises, and must deactivate their BWCs when the scene is secured as determined by the federal supervisor on the scene as designated by the sponsoring federal agency. For purposes of this policy, the term “secured” means that the scene is safe and under law enforcement control. In the event circumstances arise requiring additional law enforcement assistance to secure the scene, the TFO will end BWC recording when relieved from the scene by another law enforcement officer. TFOs are prohibited from recording: (1) undercover personnel; (2) confidential informants or confidential sources; (3) on-scene witness interviews prior to or after the operation; (4)

³ TFOs are authorized to wear and activate their recording equipment in accordance with this policy anywhere they are authorized to act as a police or peace officer under state, local, territorial or tribal law.

⁴ For the execution of a search warrant, BWCs should not be used for searches of property lawfully in government custody or control, or a search to obtain digital or electronic records executed by a third party, such as an electronic service provider or custodian of electronic records.

personnel using specialized or sensitive investigative techniques or equipment; or (5) on-scene actions by any non-law enforcement persons who are assisting law enforcement personnel prior to or after the operation. TFOs are prohibited from activating their BWC if the TFO is using specialized or sensitive investigative techniques, operating in a sensitive area, or working in an undercover or covert status on behalf of the federal task force or federal agency as determined by the federal agency sponsoring the task force. Subject to the discretion of the federal agency sponsoring the task force, TFOs generally shall not use their BWCs to record any activities related to investigations involving public corruption, medical facilities, national security, or other sensitive investigations. The Department's policy of permitting the limited use of BWCs on task forces does not apply to highly specialized or sensitive operations or groups as determined by the federal agency sponsoring the task force.

III. STORAGE OF TASK FORCE OFFICER BODY WORN CAMERA RECORDINGS IN FEDERAL TASK FORCE OPERATIONS

The TFO activating a BWC during federal task force operations is responsible for downloading, or having his/her parent agency personnel download, the resulting TFO BWC recordings. Once the TFO BWC recording is downloaded, it shall be placed onto external media (e.g., DVD, hard drive, etc.), or another mutually agreeable delivery mechanism, and promptly provided to the federal task force. The TFO parent agency will provide to the sponsoring federal agency a recording that qualifies as a "duplicate" under Federal Rule of Evidence 1001(e).⁵ The federal agency sponsoring the task force shall

⁵ Under Fed. R. Evid. 1001(e), "[a] 'duplicate' means a counterpart produced by a mechanical, photographic, chemical, electronic, or other equivalent process or technique that accurately reproduces the original."

maintain the TFO BWC recording from the TFO as appropriate in the federal agency's files.

IV. FEDERAL RECORDS

All TFO BWC recordings made during federal task force operations, including such recordings retained by the TFO's parent agency and/or in the possession of any third party engaged by the parent agency to store or process BWC recordings, shall be deemed federal records of the Department and the federal agency sponsoring the task force pursuant to the Federal Records Act. In all circumstances, TFO BWC recordings shall be treated as law enforcement sensitive information, the premature disclosure of which could reasonably be expected to interfere with enforcement proceedings, and as potential evidence in a federal investigation subject to applicable federal laws, rules, and policy concerning any disclosure or dissemination; and therefore deemed privileged absent appropriate redaction prior to disclosure or dissemination. Nothing in this policy shall be deemed to provide a right of public access to TFO BWC recordings. TFO BWC recordings are controlled by, and the property of, the Department and will be retained and managed by the federal agency sponsoring the task force. The federal agency sponsoring the task force is responsible for considering requests to release TFO BWC recordings. These records cannot be disseminated without the written permission of the Department, subject to the following exceptions:

A. Internal Dissemination

The TFO's parent agency is authorized to use TFO BWC recordings for internal investigations of its personnel consistent with the parent agency's policies and

procedures, but may not disseminate the BWC recording outside the parent agency or for public release without the written permission of the Department. The parent agency shall provide written notification to the sponsoring federal agency prior to any internal review.

B. Expedited Public Release

If TFO BWC recording(s) depict conduct committed solely by a TFO resulting in serious bodily injury or death of another, the TFO's parent agency shall notify the sponsoring federal agency⁶ and the United States Attorney as early as possible if it desires to publicly release the TFO's BWC recording(s). The sponsoring federal agency and the United States Attorney will expeditiously review the recording(s) and provide official concurrence with public release as soon as practical, unless there are specific and compelling circumstances justifying an objection to public release that cannot be resolved by redaction or other means. Upon official concurrence, the TFO's parent agency may immediately release the recording(s) with any agreed-upon redactions, giving as much advance notice as possible to the sponsoring federal agency and United States Attorney as to the time and manner of its release.

⁶ The notification may be to the Special Agent in Charge (SAC) of the federal agency sponsoring the task force or, in the case of United States Marshals Service-led task forces, the local United States Marshal and the Assistant Director (AD) / Investigative Operations Division (IOD) of the U.S. Marshals Service, and any discussions, negotiations, and concurrence may be made by the SAC or, in the case of the US Marshals Service, the local US Marshal and AD/IOD, after appropriate consultation within their agency.

V. MEMORIALIZATION

Subject to the guidance set forth in this policy, the SAC of the sponsoring federal law enforcement agency or, in the case of United States Marshals Service-led task forces, the Assistant Director of the Investigative Operations Division, is responsible for memorializing any agreement with a state and local law enforcement agency on the use of BWCs by federally deputized TFOs during federal task force operations. Upon notification to the United States Attorney, the SAC or AD/IOD shall execute a Memorandum of Understanding (MOU), or addendum to a preexisting MOU, prior to use of BWCs by TFOs that sets forth the details for the use of BWCs by TFOs on the task force consistent with this policy. Prior to entering into any agreement, the TFO's parent agency shall provide to the federal agency sponsoring the task force the details regarding the BWC system and cameras, including the details of any system protections, to the satisfaction of the federal agency, and any state or local policies or laws applicable to the TFO's use of BWCs, including any retention policies. This MOU shall make clear that TFO BWC recordings, including such recordings residing in the state/local agency's BWC system or other copies retained by the agency and/or in the possession of any third party engaged by the agency to store or process BWC recordings, are deemed to be federal records, subject to federal retention and information access laws, regulations, policies, and procedures. The federal agency sponsoring the task force will ensure that all participating agencies are informed of which participating agencies, if any, mandate BWC use by their respective TFOs, and provide all participating agencies with this policy.

APPENDIX B
Acronyms

ASAC	Assistant Special Agent in Charge
ATF	Bureau of Alcohol, Tobacco, Firearms and Explosives
BWC	Body-Worn Camera
CC	Office of Chief Counsel
CS	Confidential Source
DAD	Deputy Assistant Director
DFB	Digital Forensics Branch
DOJ	Department of Justice
FMS	Field Management Staff
FO	Office of Field Operations
FRO	Force Review Office
KEP	Kinetic Energy Projectile
OPRSO	Office of Professional Responsibility and Security Operations
OSII	Office of Strategic Intelligence and Information
OST	Office of Science and Technology
SA	Special Agent
SAC	Special Agent in Charge
SES	Senior Executive Service
SOD	Special Operations Division
SOP	Standard Operating Procedure
SSA	Supervisory Special Agent
SSD	Solid State Drives
TFO	Task Force Officer
TOB	Technical Operations Branch
UC	Undercover
USAO	United States Attorney's Office

(b) (5)

(b) (5)

(b) (5)

(b) (5)

(b) (5)

(b) (5)

(b) (5)

(b) (5)

(b) (5)

(b) (5)

(b) (5)

(b) (5)

(b) (5)

(b) (5)

(b) (5)

(b) (5)



U.S. Department of Justice
Office of the Deputy Attorney General

The Deputy Attorney General

Washington, D.C. 20530
June 7, 2021

MEMORANDUM FOR ACTING DIRECTOR, BUREAU OF ALCOHOL, TOBACCO,
 FIREARMS & EXPLOSIVES
 ACTING ADMINISTRATOR, DRUG ENFORCEMENT
 ADMINISTRATION
 DIRECTOR, FEDERAL BUREAU OF INVESTIGATION
 DIRECTOR, UNITED STATES MARSHALS SERVICE
 ASSISTANT ATTORNEY GENERAL FOR
 ADMINISTRATION
 EXECUTIVE OFFICE FOR UNITED STATES ATTORNEYS

FROM: THE DEPUTY ATTORNEY GENERAL *via Monaco*

SUBJECT: BODY-WORN CAMERA POLICY

The Department of Justice recognizes that transparency and accountability in law enforcement operations build trust with the communities we serve. Although the Department’s law enforcement components do not regularly conduct patrols or routinely engage with the public in response to emergency calls, there are circumstances where the Department’s agents encounter the public during pre-planned law enforcement operations. The Department is committed to the use of body-worn cameras (BWCs) by the Department’s law enforcement agents in such circumstances.

In October 2020, the Department announced a policy that permits state and local officers on Department of Justice Task Forces to wear and activate BWCs when the use of force is possible – while serving arrest warrants, executing other planned arrest operations, and during the execution of search warrants. Today, based on recommendations from the Department’s law enforcement components, I am directing the Acting Director of the Bureau of Alcohol, Tobacco, Firearms & Explosives; the Acting Administrator of the Drug Enforcement Administration; the Director of the Federal Bureau of Investigation, and the Director of the United States Marshals Service to develop and submit for review, within 30 days, component BWC policies that require agents to wear and activate BWC recording equipment for purposes of recording their actions during: (1) a pre-planned attempt to serve an arrest warrant or other pre-planned arrest, including the apprehension of fugitives sought on state and local warrants; or (2) the execution of a search or seizure warrant or order.

Memorandum from the Deputy Attorney General
 Subject: Body-Worn Camera Policy

Page 2

Each law enforcement component shall develop its policy and a phased implementation plan for compliance with the above directive no later than 30 days from the date of this memorandum, and shall designate a senior official with responsibility for implementation and oversight of its BWC policy. Each component also shall ensure immediately that partners serving on DOJ-sponsored task forces are aware of the current Department policy that permits state and local officers on DOJ task forces to wear and activate BWCs.

Each component's BWC policy shall include:

- the responsibilities for Department agents to carry, operate, maintain, and secure the equipment, including when to activate and deactivate BWCs;
- the type(s) of BWC equipment authorized for use;
- the duration of time and scope of the BWC footage preserved prior to its activation (i.e., buffering period);
- specialized or sensitive investigative techniques or equipment that may require different treatment under the BWC policy;
- procedures governing the collection, storage, access, retention, use, and dissemination of BWC recordings, consistent with applicable federal laws;
- procedures governing the use of BWCs by all members of Department-sponsored task forces; and
- procedures for the expedited public release of recordings in cases involving serious bodily injury or death.

In addition, as soon as practicable, each component shall:

- submit for the approval of the Department's Chief Privacy and Civil Liberties Officer a Privacy Impact Assessment of the component's planned use of BWCs and associated equipment prior to implementation of its BWC policy, and a plan for annual privacy reviews;
- consult with the Office of Records Management to ensure the component's BWC policy is fully compliant with all records-related laws, regulations, rules, policies, and guidance;
- work with the Justice Management Division to assess resource requirements to fully implement its BWC policy and build upon the resources allocated to the Department to support BWC usage in FY22; and
- design evaluation metrics that can be used to measure the impact of its BWC policy.

Memorandum from the Deputy Attorney General
Subject: Body-Worn Camera Policy

Page 3

Finally, within 90 days, the Executive Office for U.S. Attorneys should develop training for prosecutors regarding the use of BWC recordings as evidence, building on existing trainings related to the discovery implications of these recordings.

I am proud of the job performed by the Department's law enforcement agents, and I am confident that these policies will continue to engender the trust and confidence of the American people in the work of the Department of Justice.

APPENDIX F

Category	Description
ATF Special Agent BWC	Default category that should be selected for every SA BWC recording
ATF Task Force Officer (TFO) BWC	Default category that should be selected for every ATF TFO BWC recording
Use of Force – Shooting (ATF)	Selection for video that includes firearm discharge by a ATF employee
Use of Force – Shooting (TFO)	Selection for video that includes firearm discharge by a Task Force Officer
Use of Force – Other (ATF)	Selection for video that includes non-firearm use by an ATF employee (CEW, etc)
Use of Force – Other (TFO)	Selection for video that includes non-firearm use by a Task Force Officer (CEW, etc)
Use of Force – K9 Bite	Selection for video that includes a K9 bite
Serious Injury/Death to Personnel (ATF/TFO)	Selection for video that includes injury or death of either ATF employees or Task Force Officers
Serious Injury/Death to Subject	Selection for video that includes injury or death of the subject of pre-planned arrest warrant or pre-planned search warrant
Serious Injury/Death to Other	Selection for video that includes injury or death of another individual
Damage to Property (By ATF/TFO)	Selection for video that includes damage to non-ATF property caused by either ATF SA's or TFO's
Damage to ATF Property/Vehicle (by other)	Selection for video that includes damage to ATF property or vehicles by non-ATF employees or TFO's
Litigation	Selection for video that includes FOIA, Bivens, Touhy, torts, media releases

Tag	Description
3 rd Party Individual	3 rd party individual or individuals not associated with the warrant
3 rd Party Vehicle/Tag	3 rd party vehicle or tag not associated with the warrant
Arrest Warrant	Contains execution of a pre-planned arrest warrant
Complaint (IAD, OPRSO)	Video that has been identified as relevant in a complaint against the ATF or an ATF employee
Evidence Seized (By ATF/TFO)	Includes evidence seized by ATF employees or TFO's
Exigent Review Request	DOJ policy exigent review applies
Investigation (IAD)	Identified as relevant in an internal investigation
Litigation-ATF Legal Counsel	Identified as relevant in litigation
Minor Individual	Includes a minor individual
OPRSO	Relevant to OPRSO
Search Warrant	Contains the execution of a pre-planned search warrant
Sensitive Investigative Techniques	Includes sensitive investigative techniques (TOB, EUP,SRT)
Source of Information, CS or UC	Includes a source of information, confidential source or under cover individual
Training (SOD)	Training exercise
ATF Vehicle/Tag	Includes an ATF vehicle or tag
Vehicle Involved Arrest	Includes a vehicle involved arrest
FFL Investigation	Includes evidence involving investigation of a Federal Firearms Licensee
Arson Investigation	Investigation of a suspected Arson
Tag	Description
Explosives Investigation	Evidence involved in an explosives investigation
TBD	
TBD	
TBD	
TBD	
TBD	
TBD	
TBD	
TBD	
TBD	
TBD	

(b) (5)

(b) (5)

(b) (5)

(b) (5)

(b) (5)

(b) (5)

(b) (5)

(b) (5)

(b) (5)

(b) (5)

(b) (5)

(b) (5)

(b) (5)

(b) (5)

(b) (5)

(b) (5)

(b) (5)

(b) (5)

(b) (5)

(b) (5)

(b) (5)

To: (b) (6), (b) (7)(C)
Cc: (b) (6), (b) (7)(C)
From: (b) (6), (b) (7)(C)
Sent: Wed 7/28/2021 2:46:51 PM
Subject: Body-Worn Camera Lesson Plan
ATF National Academy BWC Lesson Plan.docx

Sir,

I have attached a DRAFT of the Body-Worn Camera lesson plan. Please do not disseminate, this has NOT been reviewed or approved, I just want to make sure the format is what you are looking for. Please respond with any corrections or formatting issues. Thank you!

(b) (6), (b) (7)(C)

Alcohol, Tobacco, Firearms and Explosives
16009 N. 81st Street, Suite 100
Scottsdale, AZ 85260
Special Agent Project Officer-Digital Evidence Management
Technical Project Office
Special Operations Division

(b) (6), (b) (7)(C)

CONFIDENTIALITY NOTICE: E-mail may contain confidential information that is legally privileged. Do not read this e-mail if you are not the intended recipient.

This e-mail transmission, and any documents, files or previous e-mail messages attached to it may contain confidential information that is legally privileged. If you are not the intended recipient, or a person responsible for delivering it to the intended recipient, you are hereby notified that any disclosure, copying, distribution or use of any of the information contained in or attached to this transmission is **STRICTLY PROHIBITED**. If you have received this transmission in error, please immediately notify us by reply e-mail, by forwarding this to (b) (6), (b) (7)(C) or by telephone at (b) (6), (b) (7)(C) and destroy the original transmission and its attachments without reading or saving in any manner. Thank you.

(b) (5)

(b) (5)

(b) (5)

(b) (5)

(b) (5)

(b) (5)

(b) (5)

(b) (5)

(b) (5)

(b) (5)

To: (b) (6), (b) (7)(C) (b) (6), (b) (7)(C)
(b) (6), (b) (7)(C)]
From: Vanderplow, Paul D
Sent: Tue 8/24/2021 5:02:20 PM
Subject: Fwd: Draft - **FMS NOTIFICATION MESSAGE - #21-0824.1 – PRIORITY: ROUTINE - Implementation of Federal Agent Body Worn Camera Policy**

Good afternoon

Please see slight corrections below

With these corrections we clear for issuance

Thank you

Paul

S/A Paul D. Vanderplow
ATF - Special Operations Division

(b) (6), (b) (7)(C)

(b) (6), (b) (7)(C)

Begin forwarded message:

From: (b) (6), (b) (7)(C)
Date: August 24, 2021 at 12:58:08 EDT
To: "Vanderplow, Paul D" (b) (6), (b) (7)(C)
Subject: **FW: Draft - **FMS NOTIFICATION MESSAGE - #21-0824.1 – PRIORITY: ROUTINE - Implementation of Federal Agent Body Worn Camera Policy****

See below

(b) (6), (b) (7)(C)

Alcohol, Tobacco, Firearms and Explosives
16009 N. 81st Street, Suite 100
Scottsdale, AZ 85260
Special Agent Project Officer-Digital Evidence Management
Technical Project Office
Special Operations Division

(b) (6), (b) (7)(C)

CONFIDENTIALITY NOTICE: E-mail may contain confidential information that is legally privileged. Do not read this e-mail if you are not the intended recipient.

This e-mail transmission, and any documents, files or previous e-mail messages attached to it may contain confidential information that is legally privileged. If you are not the intended recipient, or a person responsible for delivering it to the intended recipient, you are hereby notified that any disclosure, copying, distribution or use of any of the information contained in or attached to this transmission is STRICTLY PROHIBITED. If you have received this

transmission in error, please immediately notify us by reply e-mail, by forwarding this to (b) (6), (b) (7)(C) or by telephone at (b) (6), (b) (7)(C) and destroy the original transmission and its attachments without reading or saving in any manner. Thank you.

From: (b) (6), (b) (7)(C)

Sent: Tuesday, August 24, 2021 8:57 AM

To: (b) (6), (b) (7)(C); Vanderplow, Paul D (b) (6), (b) (7)(C); (b) (6), (b) (7)(C)

Subject: Draft - **FMS NOTIFICATION MESSAGE - #21-0824.1 – PRIORITY: ROUTINE - Implementation of Federal Agent Body Worn Camera Policy**

Draft – Once approved, I will distribute.

***THIS MESSAGE AUTHORIZED BY THE CHIEF, FIELD
MANAGEMENT STAFF***

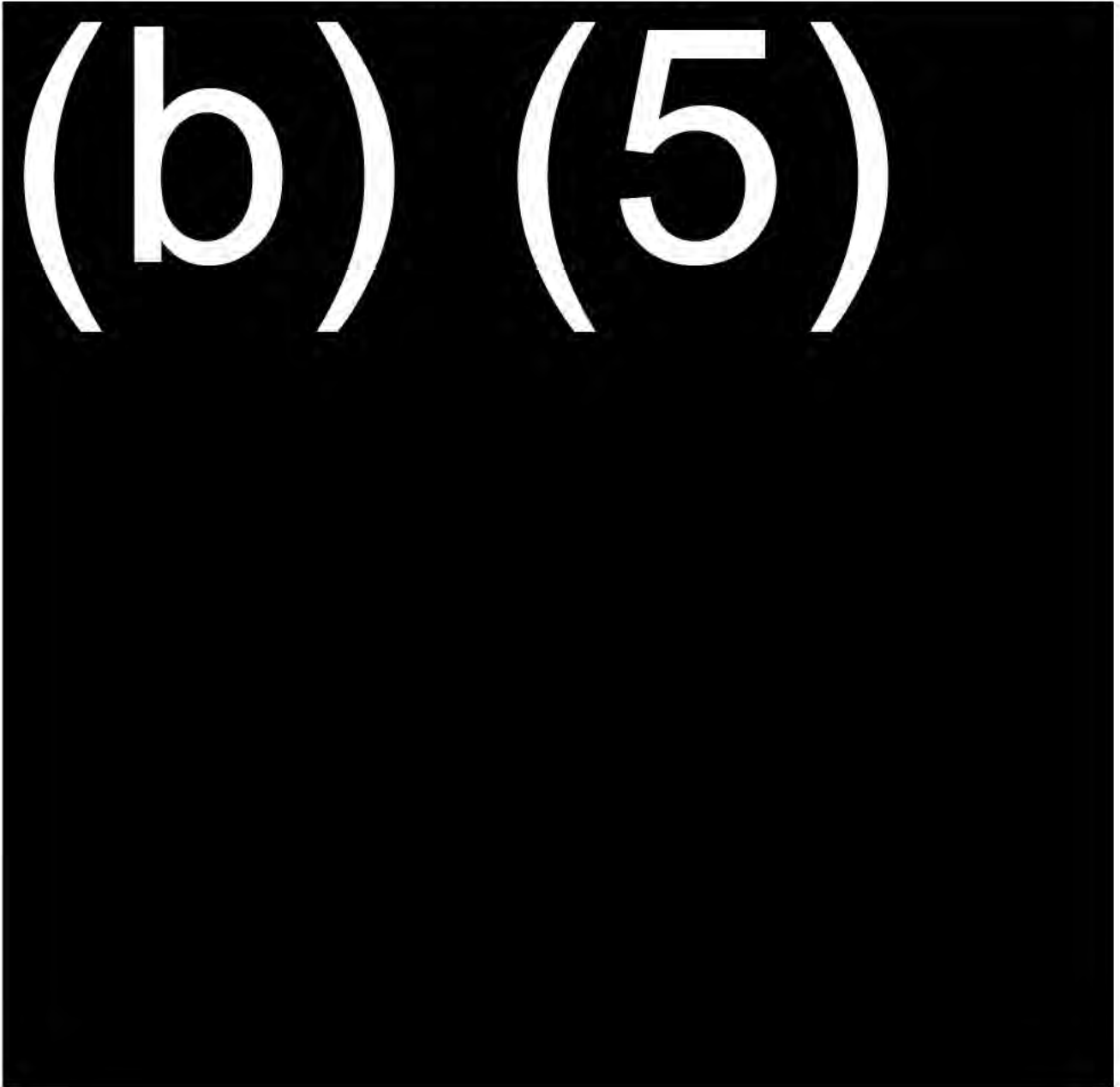

(b) (5)

To: (b) (6), (b) (7)(C); (b) (6), (b) (7)(C)
Cc: (b) (6), (b) (7)(C); (b) (6), (b) (7)(C); (b) (6), (b) (7)(C)
(b) (6), (b) (7)(C)
From: Vanderplow, Paul D
Sent: Wed 8/25/2021 3:57:59 PM
Subject: RE: **FMS NOTIFICATION MESSAGE - #21-0824.1 – PRIORITY: ROUTINE - Implementation of Federal Agent Body Worn Camera Policy**

Good Afternoon,

From my observation during training yesterday it seemed to work well.

I will defer to the SME ((b) (6), (b) (7)(C)) for her final assessment.

We will also be documenting the issues and efforts that have been undertaken to be included in the pilot assessment in February 2022.

Thank you and I also look forward to hearing (b) (6), (b) (7)(C) comments.

Paul

Paul D. Vanderplow | Division Chief
Bureau of Alcohol, Tobacco, Firearms and Explosives | Special Operations Division
O: (b) (6), (b) (7)(C) | C: (b) (6), (b) (7)(C) | E: (b) (6), (b) (7)(C)

From: (b) (6), (b) (7)(C)
Sent: Wednesday, August 25, 2021 11:10 AM
To: (b) (6), (b) (7)(C); Vanderplow, Paul D <(b) (6), (b) (7)(C)>
Cc: (b) (6), (b) (7)(C); (b) (6), (b) (7)(C) >
Subject: RE: **FMS NOTIFICATION MESSAGE - #21-0824.1 – PRIORITY: ROUTINE - Implementation of Federal Agent Body Worn Camera Policy**

Thanks (b) (6), (b) (7)(C) As I recall, SSA (b) (6), (b) (7)(C) is from Phoenix. I'd really like to hear some feedback from someone with first hand experience in Detroit ASAP.

(b) (6), (b) (7)(C)

From: (b) (6), (b) (7)(C)
Sent: Wednesday, August 25, 2021 7:16 AM
To: (b) (6), (b) (7)(C); Vanderplow, Paul D (b) (6), (b) (7)(C)
Cc: (b) (6), (b) (7)(C) >; (b) (6), (b) (7)(C)
Subject: RE: **FMS NOTIFICATION MESSAGE - #21-0824.1 – PRIORITY: ROUTINE - Implementation of Federal Agent Body Worn Camera Policy**

(b) (6), (b) (7)(C)

Thanks to support from JMD and the Network Team, we were able to conduct the training. Also, we were able to implement the DNAT solution from JMD and were able to continue training in Detroit. I spoke with SSA (b) (6), (b) (7)(C) yesterday and the network in Detroit appears to be working better and supporting the training. I will get some further details by the end of the week.

There are still some actions to be completed:

- Implement the DNAT solution for all field offices in the Detroit and Phoenix Field Divisions. Will request that change this week.
- JMD to implement a user-agent string request for Axon Upload XT
- Fully test View XL on the ESA laptops to allow viewing of a BWC video using a USB cable – Got this information last night – I believe this should work

(b) (6), (b) (7)(C)

Operations Officer

Office of Science and Technology | Bureau of Alcohol, Tobacco, Firearms, & Explosives

7S-255 | 99 New York Ave, NE | Washington D.C. 20226

Mobile: (b) (6), (b) (7)(C)

Email: (b) (6), (b) (7)(C)



PROTECTING THE PUBLIC
SERVING OUR NATION

From: (b) (6), (b) (7)(C)

Sent: Wednesday, August 25, 2021 7:10 AM

To: Vanderplow, Paul D <(b) (6), (b) (7)(C)>; (b) (6), (b) (7)(C)

Cc: (b) (6), (b) (7)(C); (b) (6), (b) (7)(C)

Subject: FW: **FMS NOTIFICATION MESSAGE - #21-0824.1 – PRIORITY: ROUTINE - Implementation of Federal Agent Body Worn Camera Policy**

Paul/(b) (6), (b) (7)(C) – This email reminds me... I know we had some network issues in Detroit and I seem to recall (b) (6), (b) (7)(C) mentioning training in Phoenix and Detroit. Do you guys know how the training went? Was the network able to support the load?

Thanks!

R

From: Chittum, Thomas L. (b) (6), (b) (7)(C)

Sent: Tuesday, August 24, 2021 5:02 PM

To: All Assistant Directors (b) (2) <(b) (2)@atf.gov>; All Deputy Assistant Directors (b) (2) <(b) (2)@atf.gov>

Subject: FW: **FMS NOTIFICATION MESSAGE - #21-0824.1 – PRIORITY: ROUTINE - Implementation of Federal Agent Body Worn Camera Policy**

FYSA. Tremendous vision by SOD, accompanied by careful execution. They recognized an opportunity, anticipated future needs, and their careful planning and analysis positioned us well ahead of our counterparts. Just wanted to keep you in the loop, as this will affect several directorates.

Tom Chittum

(b) (6), (b) (7)(C)

From: (b) (6), (b) (7)(C)
Sent: Tuesday, August 24, 2021 1:49 PM
To: ATF - FO - SES - FIELD (b) (2) @atf.gov>; ATF - FO - ASAC (b) (2) @atf.gov>; ATF - FO - DOO (b) (2) @atf.gov>
Cc: ATF - FO - SES - HQ (b) (2) FMS-ISB (b) (2) @atf.gov>; FMS Notifications (b) (2) @atf.gov>; (b) (6), (b) (7)(C) Vanderplow, Paul D (b) (6), (b) (7)(C) >(b) (6), (b) (7)(C) (b) (6), (b) (7)(C) (b) (6), (b) (7)(C) (b) (6), (b) (7)(C) (b) (6), (b) (7)(C)
Subject: **FMS NOTIFICATION MESSAGE - #21-0824.1 – PRIORITY: ROUTINE - Implementation of Federal Agent Body Worn Camera Policy**

THIS MESSAGE AUTHORIZED BY THE CHIEF, FIELD MANAGEMENT STAFF

On 01-Sep-21, ATF will be the first Department of Justice Agency to commence the Body Worn Camera (BWC) pilot program. The remaining DOJ entities will begin on or about 15-Sep-21.

In October 2019, at the direction of the Department of Justice (DOJ), ATF, along with other DOJ components, participated in a pilot program allowing Task Force Officers, (TFO) under specific parameters, to wear Body Worn Cameras (BWC) during federal planned arrest warrants or planned search warrants. Recognizing the ubiquitous nature of digital evidence, deemed federal record by DOJ, ATF SOD acquired, provided training, and ultimately implemented, a cloud based digital storage case management system, (Axon Evidence.com). In addition, ATF SOD established the Technical Project Office (TPO) to oversee the TFO BWC pilot.

In September 2020, the pilot concluded and on October 29, 2020, DOJ created a permanent policy allowing the use of body worn cameras by federally deputized Task Force Officers. This policy required all the DOJ components to maintain these BWC recordings, therefore, ATF SOD TPO established a Task Force Officer Body Worn Camera program, this program included;

- an addendum to the current TFO Memorandum of Understanding (MOU)
- acquisition of a cloud-based storage and case management system utilizing Axon Evidence.com
- TFO BWC program Standard Operating Procedures
- feedback surveys of the pilot ATF Field Divisions (Detroit, Houston, and Kansas City/Wichita)
- identification of all ATF Field Divisions affected by the new DOJ Policy
- assignment of administrative personnel for each affected division
- coordination of ATF TFO BWC program training and digital cloud storage service provider training for affected ATF Field Divisions
- restructuring of the TFO Joint Law Enforcement Operations (JLEO) onboarding process to address partner agency BWC policies
- coordination with the partner agencies to implement the addendum to the existing TFO MOU for those affected divisions

Most recently, the Office of the Deputy Attorney General (ODAG) has mandated the implementation of a federal agent BWC policy. SOD TPO has proposed a phased BWC agency implementation. Phase

I, beginning on September 1, 2021, will assess the feasibility of a permanent ATF body-worn camera program. It will also identify any infrastructure shortcomings and assist in recognizing training deficiencies. Each pilot division will provide feedback of the digital evidence platforms advantages and disadvantages. The proposed pilot locations, with the concurrence of the Assistant Director (Field Operations) and the Special Agent in Charge, (SAC) include the Detroit and Phoenix Field Divisions as well as the ATF National Academy. Agents within these field divisions, will wear BWC's during pre-planned law enforcement actions currently outlined in both the Department of Justice Use of Body-Worn Cameras Policy, ATF BWC Policy, and ATF Standard Operating Policy and Procedures. Upon conclusion of Phase I, an in-depth review will be conducted utilizing feedback from the participating divisions and other ATF directorates to begin an agency-wide implementation, if and when additional funding is provided.

Should you have any questions as this effort progresses, please send them to BWCHQ@atf.gov or contact Chief, Paul D. Vanderplow at (b) (6), (b) (7)(C)

To: Chittum, Thomas (b) (6), (b) (7)(C)
From: Vanderplow, Paul D
Sent: Tue 8/24/2021 10:30:30 PM
Subject: Re: **FMS NOTIFICATION MESSAGE - #21-0824.1 – PRIORITY: ROUTINE - Implementation of Federal Agent Body Worn Camera Policy**

Thank you.
Lot of people did a lot of great stuff with this

I'm pretty proud of the crew

Thanks again

Paul

S/A Paul D. Vanderplow
ATF - Special Operations Division
(b) (6), (b) (7)(C)
(b) (6), (b) (7)(C)

On Aug 24, 2021, at 17:20, Chittum, Thomas L. <(b) (6), (b) (7)(C)> wrote:

Seriously, nice work on this.

Tom Chittum
(b) (6), (b) (7)(C)

From: Chittum, Thomas L.
Sent: Tuesday, August 24, 2021 5:02 PM
To: All Assistant Directors (b) (2) @atf.gov>; All Deputy Assistant Directors (b) (2) @atf.gov>
Subject: FW: **FMS NOTIFICATION MESSAGE - #21-0824.1 – PRIORITY: ROUTINE - Implementation of Federal Agent Body Worn Camera Policy**

FYSA. Tremendous vision by SOD, accompanied by careful execution. They recognized an opportunity, anticipated future needs, and their careful planning and analysis positioned us well ahead of our counterparts. Just wanted to keep you in the loop, as this will affect several directorates.

Tom Chittum
(b) (6), (b) (7)(C)

From: (b) (6), (b) (7)(C)
Sent: Tuesday, August 24, 2021 1:49 PM
To: ATF - FO - SES - FIELD (b) (2) @atf.gov>; ATF - FO - ASAC (b) (2) @atf.gov>; ATF - FO - DOO (b) (2) @atf.gov>
Cc: ATF - FO - SES - HQ (b) (2) @doj365.mail.onmicrosoft.com>; FMS-ISB (b) (2) @atf.gov>

FMS Notifications <(b) (2)@atf.gov>; (b) (6), (b) (7)(C)
(b) (6), (b) (7)(C); Vanderplow, Paul D (b) (6), (b) (7)(C); (b) (6), (b) (7)(C)
(b) (6), (b) (7)(C); (b) (6), (b) (7)(C); (b) (6), (b) (7)(C)
(b) (6), (b) (7)(C); (b) (6), (b) (7)(C)

Subject: **FMS NOTIFICATION MESSAGE - #21-0824.1 – PRIORITY: ROUTINE - Implementation of Federal Agent Body Worn Camera Policy**

***THIS MESSAGE AUTHORIZED BY THE CHIEF, FIELD
MANAGEMENT STAFF***

On 01-Sep-21, ATF will be the first Department of Justice Agency to commence the Body Worn Camera (BWC) pilot program. The remaining DOJ entities will begin on or about 15-Sep-21.

In October 2019, at the direction of the Department of Justice (DOJ), ATF, along with other DOJ components, participated in a pilot program allowing Task Force Officers, (TFO) under specific parameters, to wear Body Worn Cameras (BWC) during federal planned arrest warrants or planned search warrants. Recognizing the ubiquitous nature of digital evidence, deemed federal record by DOJ, ATF SOD acquired, provided training, and ultimately implemented, a cloud based digital storage case management system, (Axon Evidence.com). In addition, ATF SOD established the Technical Project Office (TPO) to oversee the TFO BWC pilot.

In September 2020, the pilot concluded and on October 29, 2020, DOJ created a permanent policy allowing the use of body worn cameras by federally deputized Task Force Officers. This policy required all the DOJ components to maintain these BWC recordings, therefore, ATF SOD TPO established a Task Force Officer Body Worn Camera program, this program included;

- an addendum to the current TFO Memorandum of Understanding (MOU)
- acquisition of a cloud-based storage and case management system utilizing Axon Evidence.com
- TFO BWC program Standard Operating Procedures
- feedback surveys of the pilot ATF Field Divisions (Detroit, Houston, and Kansas City/Wichita)
- identification of all ATF Field Divisions affected by the new DOJ Policy
- assignment of administrative personnel for each affected division
- coordination of ATF TFO BWC program training and digital cloud storage service provider training for affected ATF Field Divisions
- restructuring of the TFO Joint Law Enforcement Operations (JLEO) onboarding process to address partner agency BWC policies
- coordination with the partner agencies to implement the addendum to the existing TFO MOU for those affected divisions

Most recently, the Office of the Deputy Attorney General (ODAG) has mandated the implementation of a federal agent BWC policy. SOD TPO has proposed a phased BWC agency implementation. Phase I, beginning on September 1, 2021, will assess the feasibility of a permanent ATF body-worn camera program. It will also identify any

infrastructure shortcomings and assist in recognizing training deficiencies. Each pilot division will provide feedback of the digital evidence platforms advantages and disadvantages. The proposed pilot locations, with the concurrence of the Assistant Director (Field Operations) and the Special Agent in Charge, (SAC) include the Detroit and Phoenix Field Divisions as well as the ATF National Academy. Agents within these field divisions, will wear BWC's during pre-planned law enforcement actions currently outlined in both the Department of Justice Use of Body-Worn Cameras Policy, ATF BWC Policy, and ATF Standard Operating Policy and Procedures. Upon conclusion of Phase I, an in-depth review will be conducted utilizing feedback from the participating divisions and other ATF directorates to begin an agency-wide implementation, if and when additional funding is provided.

Should you have any questions as this effort progresses, please send them to BWCHQ@atf.gov or contact Chief, Paul D. Vanderplow at (b) (6), (b) (7)(C)

To: (b) (6), (b) (7)(C)
From: Vanderplow, Paul D
Sent: Wed 6/30/2021 11:08:01 PM
Subject: FW: Information - House in Order Task Force
ATF - PRC - Committee Report - v20-0929.pdf
ATF - PPRTF - Memo - Executive Summary and Transmittal.pdf
SOD - Memo - Committee Recommendations - 20-1130.pdf

For your reading pleasure

Enjoy

Paul

Paul D. Vanderplow | Division Chief
Bureau of Alcohol, Tobacco, Firearms and Explosives | Special Operations Division
O: (b) (6), (b) (7)(C) | C: (b) (6), (b) (7)(C) E: (b) (6), (b) (7)(C)

From: Vanderplow, Paul D
Sent: Wednesday, June 30, 2021 7:03 PM
To: (b) (6), (b) (7)(C)
Subject: Information - House in Order Task Force

Good Evening,

Attached are documents presented to the Director's Office in support of this effort.

The funding I am requesting is from #1 and #5 in the Committee Recommendations memo attached.

The screen shot is the transmission from the Team leader – AD Hughes to the other ADs for the final briefing on 05-Nov-20

NOV 5th: Final Briefing - House in Order Task Forces



Hughes, Alphonso J.

To: Nunez, Celine; Chittum, Thomas L.; McDermond, James E.; Roessner, Joel J.; Vanderplow, Paul D.; Leadingham, Mickey D.; Forcelli, Peter; Chabira, S. Roy
Cc: Hughes, Alphonso J.

1 2 3 4 5 6 7 8 9 10 11

Colleagues - the final briefing for Director Lombardo is scheduled for Thursday November 5th after the 1:00pm AD staff meeting. I will add it to the calendar as soon as I can. Please plan to be

Today, 10/23/20 we will NOT have a task force meeting. We will schedule a deconfliction meeting before NOV 5th.

Enjoy your Friday everyone!

On Oct 12, 2020, at 9:39 PM, Hughes, Alphonso J. (b) (6), (b) (7)(C) wrote:

Colleagues -

Please find the combined final brief with all elements from Team 1 and Team 2 compiled. This is the final version for tomorrow's brief. There has been no substantive changes to our brief all in the AM.

V/R,

Alphonso J. Hughes
Assistant Director, EPS
DOJ/Bureau of ATF (5.N-600)
Office: (b) (6), (b) (7)(C)
Mobile: (b) (6), (b) (7)(C)

<Final - House in Order Joint Task Forces - Culture Change Initiative2020.v10 (Final Brief).pptx>

Thanks

Paul

Paul D. Vanderplow | Division Chief
Bureau of Alcohol, Tobacco, Firearms and Explosives | Special Operations Division
O: (b) (6), (b) (7)(C) | C: (b) (6), (b) (7)(C) | E: (b) (6), (b) (7)(C)

(b) (5)

(b) (5)

(b) (5)

(b) (5)

(b) (5)

(b) (5)

(b) (5)

(b) (5)

(b) (5)

(b) (5)

(b) (5)

(b) (5)

(b) (5)

(b) (5)

(b) (5)

(b) (5)

(b) (5)

(b) (5)

(b) (5)

(b) (5)

(b) (5)

(b) (5)

(b) (5)

(b) (5)

(b) (5)

(b) (5)

(b) (5)

(b) (5)

(b) (5)

(b) (5)

(b) (5)

(b) (5)

(b) (5)

(b) (5)

(b) (5)

(b) (5)

(b) (5)

(b) (5)

(b) (5)

(b) (5)

(b) (5)

(b) (5)

(b) (5)

(b) (5)

(b) (5)

(b) (5)

(b) (5)

(b) (5)

(b) (5)

(b) (5)

(b) (5)

(b) (5)

(b) (5)

(b) (5)

(b) (5)

(b) (5)

(b) (5)

(b) (5)

(b) (5)

(b) (5)

(b) (5)

(b) (5)

(b) (5)

(b) (5)

(b) (5)

(b) (5)



U.S. Department of Justice

Bureau of Alcohol, Tobacco,
Firearms and Explosives

Office of the Director

November 4, 2020

MEMORANDUM TO: Acting Director
Associate Deputy Director

FROM: Assistant Director
Office of Professional Responsibility and Security Operations

Assistant Director
Office of Enforcement Programs and Services

SUBJECT: Transmission of Law Enforcement Policy Review Task Force Final
Report

On behalf of the Executive Committee members, Subject Matter Experts and Field Review Panel, it is our honor to submit the attached report of information/findings and supporting documentation for the Law Enforcement Policy Review Sub -Taskforce *Review of Existing Protocol in Enforcement Operations*.

Upon extensive review of seven (7) identified critical Areas of Focus, this Committee can summarize the following:



This task force submits this comprehensive narrative report with unanimous input and backing of its governing Executive Committee, Subject Matter Experts and Field Review

Acting Director
Associate Deputy Director

Panel. This report is not only viewed as a summative document, but also as reference material for the critical areas outlined herein moving forward.

Should you have any questions or if additional information is needed, the Committee stands ready to respond and make any presentations to you or any designated entities.

Very Respectfully,

(b) (6)

Celinez Nunez
AD, OPRSO

(b) (6)

Alphonso J. Hughes
AD, EPS



U.S. Department of Justice

Bureau of Alcohol, Tobacco,
Firearms and Explosives

Special Operations Division

December 9, 2020

701200:PDV

MEMORANDUM TO: Assistant Director
Field Operations

FROM: Chief
Special Operations Division

SUBJECT: Program investment recommendations from
the ATF Committee on Law Enforcement Program Review

In July 2020, the Bureau of Alcohol, Tobacco, Firearms and Explosives (Acting) Director Regina Lombardo requested a review of critical areas of ATF's law-enforcement policy portfolio to ensure that these areas adequately protect ATF personnel in the administration of their duties.

Upon extensive review of eight-(8) identified critical areas, this Committee can summarize the following:

(b) (5)

Assistant Director
Field Operations

